

SafeStop™

User's Manual

SafeStop™ ES-220

Wireless Emergency Stop System for Unmanned Vehicles



✓ **Multi-Level Control**

✓ **Long Range - 6 mi LOS**

✓ **Handheld Transmitter**

✓ **Operator Feedback**

For technical assistance and repairs, please use the following contact information:

Mailing Address	Email & Phone Support
TORC Technologies	support@torctech.com
2200 Kraft Dr, Ste 1325	www.torctech.com
Blacksburg, VA 24060	Phone: 540-443-9262

Copyright © 2009 TORC Technologies, LLC, All Rights Reserved.

All information contained in this manual is believed to be accurate at the time of printing, however, TORC Technologies, LLC reserves the right to make modifications to the specifications and operation of this product without obligation to notify any person or entity of such revision.

TABLE OF CONTENTS

1	ASSIGNMENT OF LIABILITY	5
2	GENERAL SAFETY INFORMATION	6
3	PACKAGE CONTENTS	8
4	SAFESTOP™ SYSTEM OVERVIEW	9
5	SAFESTOP™ SYSTEM SPECIFICATIONS	10
6	TRANSMITTER UNIT	11
6.1	Transmitter Switch Detail	12
6.2	Transmitter Power Connector	12
6.3	Transmitter LED Indicator Detail	13
6.4	Transmitter Audible Alarm Detail.....	13
7	RECEIVER UNIT	15
7.1	POWER/SERIAL Connector Detail	16
7.2	STOP/PAUSE Connector Detail	16
7.3	Receiver Switch Detail.....	17
7.4	Receiver LED Indicator Detail	17
7.5	Receiver RS-232 Communications Format	17
8	USER CONFIGURATION MENU	19
8.1	Channel Number	20
8.2	Timeout Action.....	20
8.3	Timeout Delay.....	21
8.4	External Stop Polarity.....	21

8.5	Latching Action.....	21
8.6	Restore Defaults.....	22
8.7	Save Settings.....	22
9	SYSTEM INTEGRATION.....	23
9.1	Charging the Transmitter Battery.....	23
9.2	Installing the Antennas.....	23
9.3	Installing the Receiver Cables into the Vehicle System.....	24
9.4	Example STOP/PAUSE Wiring Schematics.....	24
9.5	Example Latch/External Stop Wiring Schematics.....	25
9.6	Verify Proper Operation of the System.....	25
10	PHYSICAL DIMENSIONS.....	27
10.1	ES-220T Transmitter Dimensions.....	27
10.2	ES-220R Receiver Dimensions.....	28
10.3	Receiver Mounting Template.....	29
11	FCC COMPLIANCE.....	30
12	LIMITED WARRANTY.....	30

1 ASSIGNMENT OF LIABILITY

TORC Technologies, LLC does not assume any responsibility for the safe operation of any vehicle, machinery, or related equipment connected to the SafeStop™ system. This product has been tested for proper functionality and safe operation, however, it is the responsibility of the consumer to ensure the safe operation and testing of all connected components.

By using the SafeStop™ system, the customer agrees to accept full responsibility and legal liability for any systems connected to the device, and to indemnify, defend and hold harmless TORC Technologies, LLC from all associated legal liability and recourse.

Each operator should read the entire user manual prior to using the device. Failure to read, understand, and strictly follow these instructions could result in serious personal injury and/or property damage.

2 GENERAL SAFETY INFORMATION

The following symbols are used throughout the user manual to indicate a particularly hazardous condition.



WARNING: Indicates a hazardous condition that could result in serious injury or loss of life if not performed properly.



CAUTION: Indicates a hazardous condition or procedure that could result in damage to this product, or loss related to equipment malfunction.



NOTE: A note indicates information that may not be applicable regarding system safety but needs to be known for best system performance.

Use Redundant Safety Measures

This product is not intended to be used as the only safety stop device. It is the user's responsibility to ensure that adequate and redundant safety measures are implemented for the system that this product is used.

Use Proper Supplied Accessories

To prevent damage to the product, use only the recommended accessories, including power adapters, antennas, and cables.

Observe All Connector Ratings

To avoid shock hazard and/or damage to the product, do not exceed any voltage or current specifications on any of the connectors.

Do Not Charge Unattended

To avoid fire hazard and/or damage to the product, monitor the SafeStop™ transmitter when connected to an external power supply.

Do Not Operate With Suspected Failures

If you suspect there is damage to the product, contact TORC Technologies to have it inspected before further use.

Do Not Modify or Disassemble

To avoid shock hazard and/or damage to the product, do not attempt to open the case, make modifications, or repair the device. Opening, modifying or repairing this device will void any applicable warranty and could prevent the device from operating properly.

Do Not Operate in Wet/Damp Conditions

To avoid shock hazard and/or product malfunction, do not operate in a wet or damp environment.

Do Not Operate in Explosive Atmosphere

To avoid a fire hazard, do not operate in an explosive atmosphere, such as in the presence of flammable liquids or gases.

Use Within Range

To prevent unreliable operation, do not use this product outside of its specified range. A range check should be performed before using the SafeStop™ system.

Maintain Minimum Separation Distance

To prevent receiver overload (possibly causing loss of link), and to ensure operator safety, maintain a minimum operating distance of 10 feet between the antennas of the SafeStop™ system.

3 PACKAGE CONTENTS

After unpacking the contents of the SafeStop™ ES-220 System, please verify the contents of the package includes the following items:

- ES-220T SafeStop™ Transmitter unit
- ES-220R SafeStop™ Receiver unit
- ES-220T-RDA Rubber Duck Antenna for ES-220T Transmitter
- ES-220T-ACC AC Power Adapter/Charger for ES-220T Transmitter
- ES-220T-DCC Automotive Power Adapter/Charger for ES-220T Transmitter
- ES-220R-MMA Antenna for ES-220R Receiver w/Magnetic Mount and 12' Cable
- ES-220R-PRC 6' Relay Cable for ES-220R Receiver (Yellow/Blue/White/Green)
- ES-220R-PSC 6' Power and Serial Cable for ES-220R Receiver



SafeStop™ Transmitter (ES-220T)
(rubber duck antenna installed)



SafeStop™ Receiver (ES-220R)



Transmitter Rubber Duck Antenna
ES-220T-RDA



AC Power Adapter
ES-220T-ACC



Automotive Power Adapter
ES-220T-DCC



Receiver Magnetic Mount Antenna
ES-220R-MMA



Receiver Power and Serial Cable
ES-220R-PSC



Receiver Relay Cable
ES-220R-PRC

4 SAFESTOP™ SYSTEM OVERVIEW

The SafeStop™ ES-220 multi-level wireless emergency stop system consists of the ES-220T transmitter and the ES-220R receiver. The SafeStop™ system provides the ability to safely disable an unmanned or autonomous vehicle from a remote location up to 6 miles away. The compact lightweight transmitter contains an internal rechargeable battery that allows the SafeStop™ system to operate up to 30 hours on a single charge. Two independently controlled contacts allow a vehicle to be placed in a paused state as well as disable power to actuators, fuel valves, etc. An audible alarm and indicator lights provide user feedback of contact position, link status, and battery life. Additionally, a serial port is provided for interfacing to an onboard computer, and a bypass switch allows for manual override of the system.

5 SAFESTOP™ SYSTEM SPECIFICATIONS

Performance	
Operating Distance:	6 mi.* (line-of-sight)
Update Rate:	25 Hz
Wireless Link	
Frequency Band:	902 - 928 MHz
Transmit Power:	743 mW
Modulation:	FHSS FSK
Channels:	32
Encryption:	56-bit DES Key
FCC Approved:	Yes
Transmitter Electrical	
ES-220T Battery Life:	30 hours*
ES-220T Input Voltage (charging):	12 VDC ±10%
ES-220T Power Consumption:	15 W
Receiver Electrical	
ES-220R Input Voltage:	9-30 VDC
ES-220R Power Consumption:	9 W
Vehicle Interface / Contact Ratings	
Digital Communications:	RS-232
Data Rate:	9600 baud
Run/Stop Contact Rating:	5A @ 30 VDC, 5A @ 250 VAC
Run/Pause Contact Rating:	5A @ 30 VDC, 5A @ 250 VAC
Visual Indicators	
Power:	Bicolor LED
Link Status:	Bicolor LED
Pause Relay:	Bicolor LED
Stop Relay:	Bicolor LED
Charging (Transmitter Only):	Bicolor LED
Audible Alarm (Transmitter Only)	
Link Lost:	Continuous Tone
Low Battery:	Three Beeps
Environmental	
Dust / Water Resistance:	IP50
Operational Temperature:	0°C - 70°C
Operational Humidity:	10% - 90%, non-condensing
Operational Shock Rating:	10 g

* Performance data based on optimal conditions

6 TRANSMITTER UNIT

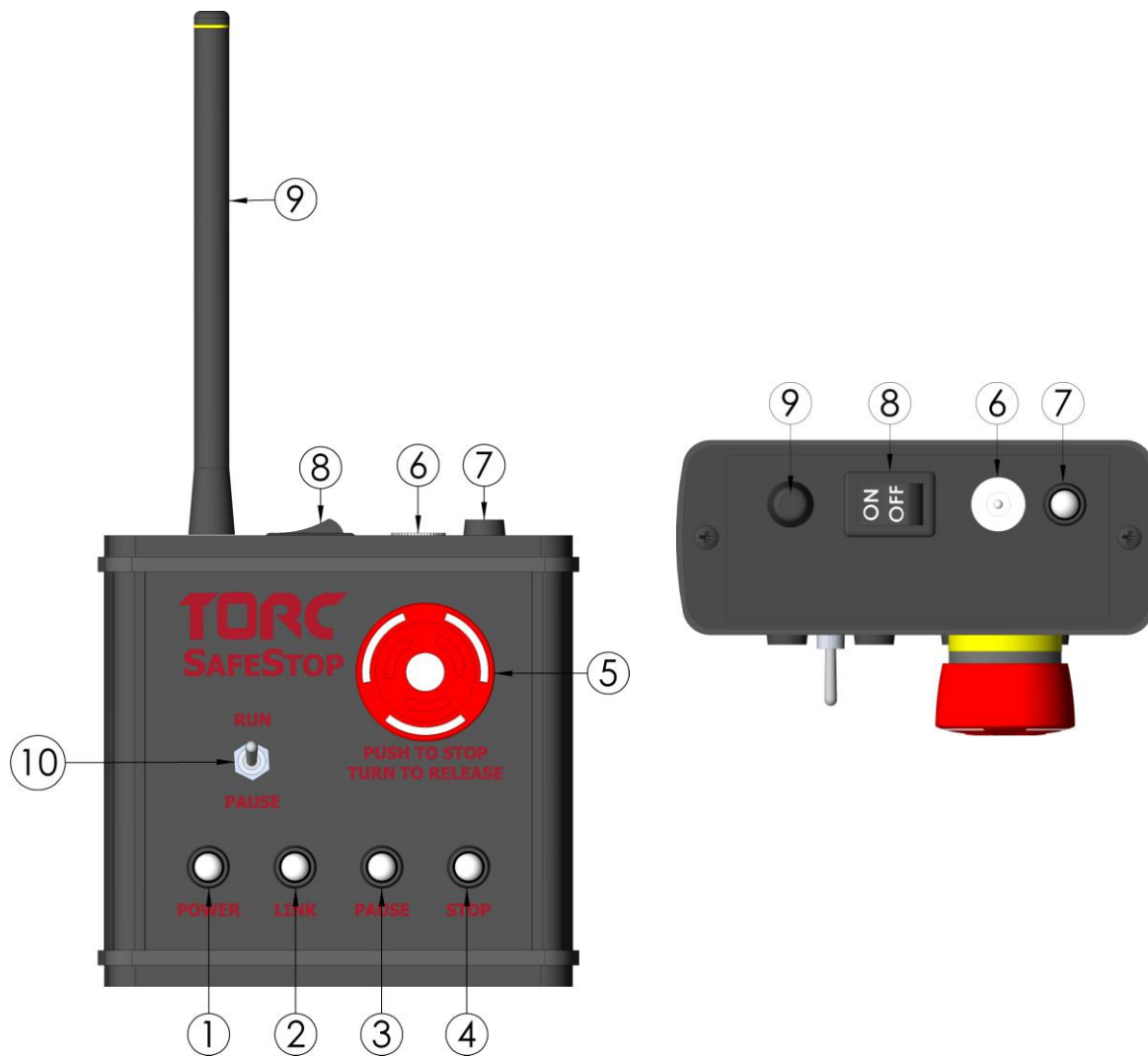

Item	Description
1	Power Status Indicator
2	Link Status Indicator
3	Pause Contact Indicator
4	Stop Contact Indicator
5	Run/Stop Push-to-stop, turn-to-release button
6	Charging Plug
7	Charge Status Indicator
8	Power Rocker Switch
9	Dipole Antenna
10	Run/Pause toggle switch

6.1 Transmitter Switch Detail

There are three switches located on the transmitter: the power rocker switch, the Pause/Run toggle switch, and the push-to-stop/turn-to-release Stop/Run button.

When the power rocker switch is in the “ON” position, the transmitter is powered. With the switch in the “OFF” position, the transmitter is shut down, and will no longer receive or transmit data.

The Pause/Run toggle switch is used to activate or deactivate the Pause relay on the receiver. With the switch in the “PAUSE” or down position on the transmitter, the Pause contact is deactivated on the receiver. When deactivated, pin 6 and pin 5 of the STOP/PAUSE connector are connected. When the switch is in the up or “RUN” position, pins 4 and 5 are connected.

The push-to-stop/turn-to-release red Stop button controls the Stop relay on the ES-220R receiver. When pushed, the button is in the Stop position, and deactivates the Stop contact on the receiver. When the Stop contact is deactivated, pin 3 is connected to pin 2 of the STOP/PAUSE connector. When the button is turned, or released, pins 1 and 2 are connected.

6.2 Transmitter Power Connector

The transmitter Power Connector is used for charging the internal rechargeable transmitter battery and powering the transmitter off of external power. The Power Connector is a 2.1mm center positive 12 VDC power plug.



WARNING: Do not leave the ES-220T unattended while charging the battery.



WARNING: Only charge battery with one of the supplied 12 VDC adapters (P/N: ES-220T-ACC or ES-220T-DCC).



WARNING: Connecting a power supply over 12 VDC will cause damage to the ES-220T transmitter.

6.3 Transmitter LED Indicator Detail

Indicator	Status	Meaning
Power	Off	Unit power is off
	Red	Less than 20% battery life remaining
	Green	Unit power is on
Link	Off	Bypass mode activated
	Red	Communications link has been lost
	Green	Communications link is active
Pause	Off	State of Pause contact is unknown due to lost link
	Red	Pause: Pins 5 and 6 connected (Relay Connector)
	Green	Run: Pins 5 and 4 connected (Relay Connector)
Stop	Off	State of Stop contact is unknown due to lost link
	Red	Stop: Pins 2 and 3 connected (Relay Connector)
	Green	Release: Pins 2 and 1 connected (Relay Connector)
Charge Status	Off	External Power Not Connected
	Red	Battery Charging
	Green	Battery Fully Charged

6.4 Transmitter Audible Alarm Detail

The ES-220T transmitter features an audible alarm to indicate an error condition that requires immediate user intervention. If the communication link is lost, the ES-220T is no longer in communication with the receiver, and the transmitter emits a constant tone. The ES-220T transmitter needs to be brought back within range of the receiver before operation can resume.

If the battery drops to approximately 20% of its total capacity, the audible alarm will start to sound 3 short tones every 10 seconds. If this occurs, power the transmitter off external power

with either the supplied AC adapter (P/N: ES-220T-ACC), or automotive adapter (P/N: ES-220T-DCC).

Alarm	Meaning
Continuous	Communication link with receiver has been lost
3 Short Beeps	Low battery

7 RECEIVER UNIT

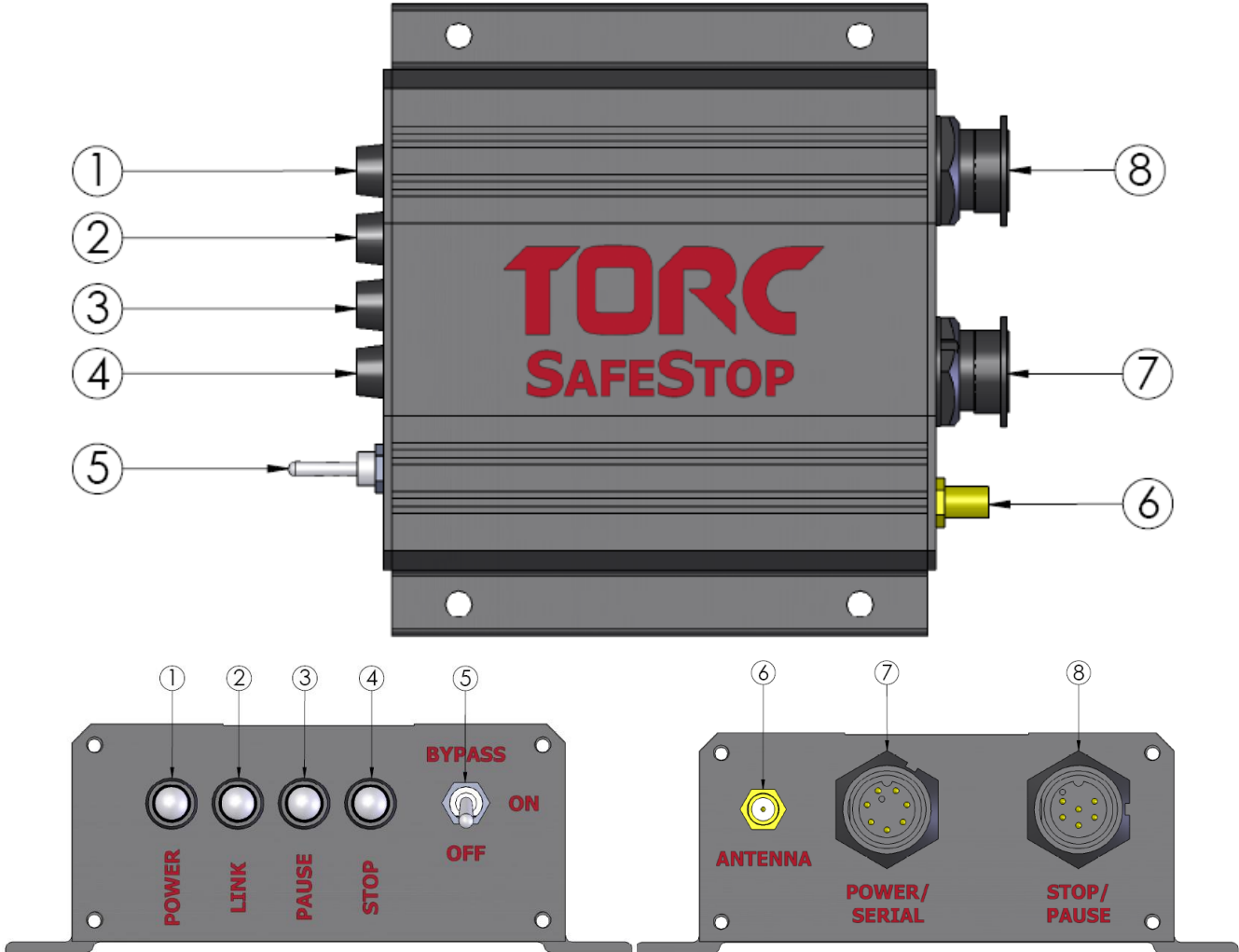

Item	Description
1	Power Status Indicator
2	Link Status Indicator
3	Pause Contact Indicator
4	Stop Contact Indicator
5	Power/Bypass Switch
6	RP-SMA Antenna Connection
7	Power/Serial Connector
8	Stop/Pause Connector

7.1 POWER/SERIAL Connector Detail

The POWER/SERIAL connector is used to supply power to the ES-220R receiver and for RS-232 communications.

Mating connector: Switchcraft EN3C8F

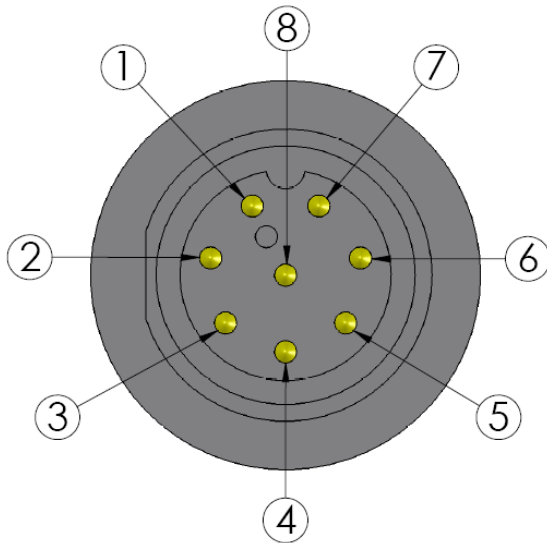

Item	Description
1	VIN (Red)
2	Power GND (Black)
3	Tx (DE9 Pin 2)
4	Rx (DE9 Pin 3)
5	Latch\External Stop (blue)
6	Signal GND (DE9 Pin 5)
7	User Configuration (white)
8	Factory use only

7.2 STOP/PAUSE Relay Connector Detail

The STOP/PAUSE relay connector is used for the contact connections of both the Run/Pause, and Release/Stop contacts.

Mating connector: Switchcraft EN3C6F

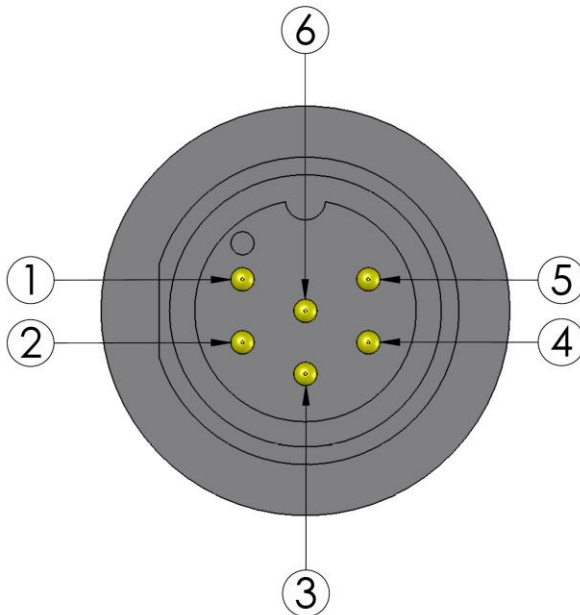

Item	Description
1	Stop: Connected when running (Orange)
2	Stop: Common (Blue)
3	Stop: Connected when stopped (not cabled)
4	Pause: Connected when running (White)
5	Pause: Common (Green)
6	Pause: Connected when stopped (not cabled)

7.3 Receiver Switch Detail

The Power/Bypass switch is a three position toggle switch used to power the receiver and for placing the unit in Bypass mode. With the switch in the middle or “ON” position, the receiver is in normal operation, and accepts commands from the transmitter. The down, or “OFF” position of the switch cuts power to the receiver. With the switch in the up or “BYPASS” position, the receiver will activate the relays, placing both the Stop and Pause relays in a run state, and turn off the “LINK” indicator.



WARNING: While in Bypass Mode, the receiver will not accept Stop or Pause commands from the transmitter.



CAUTION: The power toggle switch must be first pulled out to be actuated.

7.4 Receiver LED Indicator Detail

Indicator	Status	Meaning
Power	Off	Unit power is off
	Green	Unit is powered on
Link	Off	Bypass mode activated
	Red	Communications link to transmitter has been lost
	Green	Communications link to transmitter is active
Pause	Red	Pause: Pins 5 and 6 connected (Relay Connector)
	Green	Run: Pins 5 and 4 connected (Relay Connector)
Stop	Red	Stop: Pins 2 and 1 connected (Relay Connector)
	Green	Release: Pins 2 and 3 connected (Relay Connector)

7.5 Receiver RS-232 Communications Format

The ES-220R continuously monitors the status of the relay outputs and communication link. This information is sent serially over RS-232 communications. The data bit format is set to communicate at 9600bps, 8 data bits, 1 stop bit, no parity, and no flow control.

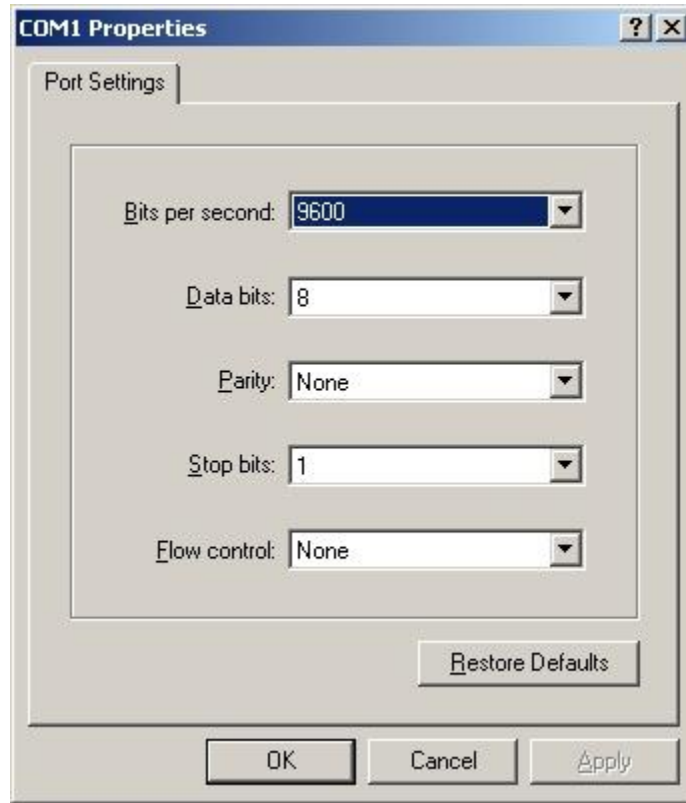

HyperTerminal Port Settings

The serial protocol consists of 3 data bytes followed by a carriage return and line feed for a total of 5 bytes updated at a frequency of 25 Hz in the following format:

<Link Status><Run/Pause Status><Release/Stop Status><CR><LF>

Byte	Value	Description
<i><Link Status></i>	X	Link Lost
	B	Bypass Mode
	L	Link Active
<i><Run/Pause Status></i>	R	Run
	P	Pause
<i><Release/Stop Status></i>	R	Release
	S	Stop

Upon startup, the ES-220R will perform a diagnostic check and transmit the results over the RS-232 communications link. An example startup screen can be seen below. After the initial diagnostic outputs, the standard serial output protocol will be continuously displayed.

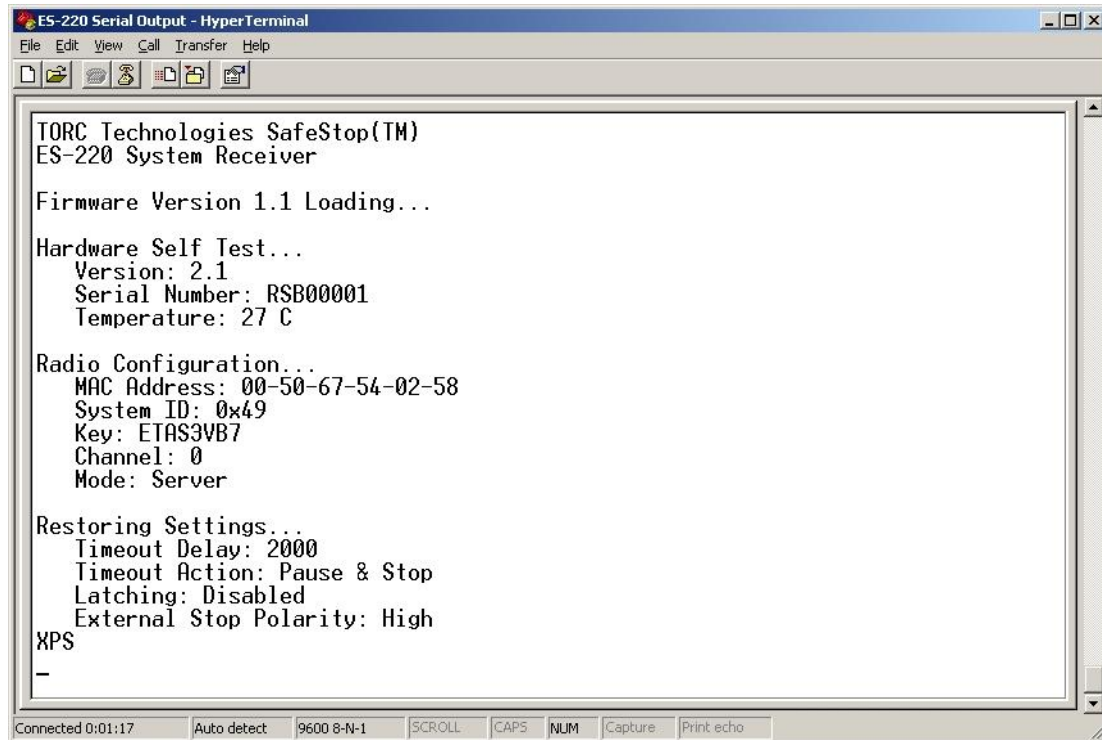

```

ES-220 Serial Output - HyperTerminal
File Edit View Call Transfer Help
TORC Technologies SafeStop(TM)
ES-220 System Receiver

Firmware Version 1.1 Loading...

Hardware Self Test...
Version: 2.1
Serial Number: RSB00001
Temperature: 27 C

Radio Configuration...
MAC Address: 00-50-67-54-02-58
System ID: 0x49
Key: ETAS3VB7
Channel: 0
Mode: Server

Restoring Settings...
Timeout Delay: 2000
Timeout Action: Pause & Stop
Latching: Disabled
External Stop Polarity: High
XPS
-

Connected 0:01:17  Auto detect  9600 8-N-1  SCROLL  CAPS  NUM  Capture  Print echo
    
```

Example RS-232 Output Terminal

8 USER CONFIGURATION MENU

The ES-220 SafeStop™ system has multiple configuration options that can be customized by the user. These options include the RF channel number, timeout delay, timeout action, latching action, and external emergency stop input polarity. These options can be accessed through the user configuration menu over the ES-220's serial communication cable. The user configuration menu is entered by asserting the white User Configuration wire high on the power serial cable prior to powering the receiver. Once the user has entered the desired configuration options the changes must be committed by selecting the "Save Settings" menu option. System power must then be cycled for changes to take effect.

```

ES-220 Serial Output - HyperTerminal
File Edit View Call Transfer Help

Radio Configuration...
  MAC Address: 00-50-67-54-02-58
  System ID: 0x49
  Key: ETAS3VB7
  Channel: 0
  Mode: Server

Restoring Settings...
  Timeout Delay: 2000
  Timeout Action: Pause & Stop
  Latching: Disabled
  External Stop Polarity: High
XPS

*****USER CONFIGURATION MODE*****
  1: Channel #
  2: Timeout Action
  3: Timeout Delay
  4: External Stop Polarity
  5: Latching On/Off
  6: Restore Defaults
  7: Save Settings
>>

Connected 0:01:43  Auto detect  9600 8-N-1  SCROLL  CAPS  NUM  Capture  Print echo
    
```

Example User Configuration Menu

8.1 Channel Number

The transmitter and receiver of each ES-220 SafeStop™ system operate on one of 32 available wireless channels. If multiple SafeStop™ systems are used simultaneously within range of one another, each system should be on a unique channel for proper operation. In the event multiple units are on the same channel and operating in the same area, the user can select a different channel from the user configuration menu.

Changing the RF channel number is a setting that must be changed in both the ES-220R receiver and the ES-220T transmitter although the user only needs to change this setting once in the receiver’s user configuration menu. The transmitter is configured wirelessly by the receiver after the “Save Settings” option is selected, where the user will be prompted to reset power to the transmitter. Once communications between the transmitter and receiver have been restored, the new settings will be applied followed by a confirmation message over the serial link.

8.2 Timeout Action

During a loss of communications, the SafeStop™ ES-220 can be configured in one of two ways: open both pause and stop contacts, or open just the pause contact while the stop contact remains in its current state. This timeout action will take effect after communications between

the receiver and transmitter have been lost for the time specified by the timeout delay. The default setting for the timeout action is set to open both the pause and stop contacts.

8.3 Timeout Delay

The timeout delay of the Safe Stop determines the response time of the system during a loss of link action. If communications are lost between either the transmitter or the receiver, the user configurable timeout action will take effect after the timeout delay has elapsed. The delay can be set from a range of 600ms to 5000ms through the user configuration prompt. A change in the timeout delay requires settings to be changed on both the transmitter and the receiver. This requires the transmitter power to be cycled after the “Save Settings” option has been selected as directed by the prompt on screen. After cycling power to the transmitter, the receiver will wirelessly configure the transmitter with the desired settings, and a confirmation message will be displayed. The default timeout delay for the ES-220 SafeStop™ systems is 2000ms.

8.4 External Stop Polarity

The Latch/External Stop pin is used to clear disable events on the receiver when latching is enabled. This pin is also used as a way to add external wired emergency stop buttons to the vehicle system. Depending on the polarity selected, driving this line high or low will result in the opening of the stop contact of the receiver. By default the receiver is programmed to stop when the Latch/External Stop wire is tied high to VIN. The internal pull-down within the receiver can allow for this pin to be left unconnected if this functionality is not used.

With the “Stop on High External Input” option selected, connecting the Latch/External Stop line high will cause the stop relay to open, placing the system in a stopped state. Multiple external buttons or switches can be used in parallel as seen in the wiring example below. If the “Stop on Low External Input” option is selected, pulling the Latch/External Stop line low will cause the stop relay to open. There is an internal pull-down within the receiver that will keep the receiver in the stop position unless the Latch/External Stop pin is driven high. Multiple normally closed switches can be used in a series configuration with low external stop polarity selected.

The example wiring diagram below shows an example of how additional emergency stop switches can be used to enable stop events and clear latch states by toggling one of the emergency stop buttons during both polarity modes.

8.5 Latching Action

One of the added features of the ES-220 system is the ability to latch the stop contact on the receiver, requiring a stop event to be manually cleared before resuming operation. With latching enabled, clearing each stop or disable event is a two step process that first requires the

release of the emergency stop button on the transmitter, followed by toggling the blue Latch/External Stop wire of the power serial cable to either VIN, or GND depending on the settings in the “External Stop Polarity” menu.

If external stop polarity is set to high, the Latch/External Stop line must be toggled to VIN and then back to GND or left floating to clear the stop signal. The opposite is true when the external stop polarity is set to low.

By default latching is disabled, and a release of the emergency stop button on the transmitter will clear the emergency stop event.



NOTE: The Latch/External Stop input easily integrates additional pushbuttons with the SafeStop™ system. For implementation examples, refer to the wiring schematics in the System Integration section.

8.6 Restore Defaults

Restoring defaults to the receiver must only be done when communications between the transmitter and receiver have been lost and can not be restored due to a settings change failure during user configuration. Restoring defaults on the receiver will render the receiver unable to communicate with the transmitter and require the transmitter to be reset through an internal jumper.



WARNING: Restoring defaults on the receiver will require a jumper to be installed internally on the transmitter. If restoring transmitter defaults is required, follow the instructions outlined in the application note for “Restoring Defaults in the SafeStop™ ES-220T.”

8.7 Save Settings

All changes made in the user configuration menu will not be changed unless the “Save Settings” option in the user configuration menu is selected. If the RF channel number or timeout delay are changed, the user will then be asked to cycle power to the transmitter for settings to be committed. After any changes have been made through the user configuration menu, power to both the transmitter and receiver must be cycled for the changes to take effect.

9 SYSTEM INTEGRATION

Before your remote relay system can be used, you need to perform the following steps: fully charge the transmitter battery, install the antennas, install the receiver cables, and verify proper system operation.

9.1 Charging the Transmitter Battery

Before using the Remote Relay System, the transmitter battery must be fully charged for 5 hours. The transmitter can be charged using the supplied AC adapter (P/N: ES-220T-ACC), or the 12VDC automotive power adapter (P/N: ES-220T-DCC). To charge the battery, plug one of the supplied power supplies into the charging plug. When connected to an external power supply, the Charge Indicator LED should be red while the battery is charging and green when the battery is fully charged. Operating the SafeStop™ system while connected to external power will not drain the battery or reduce the charge time as long as the power adapter is properly connected.



WARNING: Do not leave the ES-220T transmitter unattended while charging the battery.



WARNING: Only charge battery with one of the supplied adapters (P/N: ES-220T-ACC or ES-220T-DCC).

9.2 Installing the Antennas

Before turning power to either the ES-220T transmitter or ES-220R receiver on, the device antennas must be connected. The supplied antenna with magnetic mount and 6' coaxial cable (P/N: ES-220R-MMA) installs on the receiver's antenna connector. Install the antennas by threading them clockwise onto the corresponding antenna jacks.



CAUTION: Do not over tighten antenna connectors.



CAUTION: Antennas must be installed before applying power to the SafeStop™ system.

The receiver antenna is connected to a magnetic base that may be attached to a ferrous object. The antenna should be mounted to the highest point possible, away from any other communications antennas and sources of electro-magnetic interference, such as engines and electric motors. Care should be taken when routing the coaxial cable to avoid tight bends smaller than 1" radius.

9.3 Installing the Receiver Cables into the Vehicle System

The installation of the receiver consists of properly wiring the “POWER/SERIAL” connector and the “STOP/PAUSE” connector. Using the supplied power cable (P/N: ES-220R-PSC), power the receiver using a power source (not included) capable of 9 Watts at 9-30V. The power cable’s (P/N: ES-220R-PSC) red wire should be connected to the positive terminal, and the black wire should be connected to ground. If using the RS-232 output, the DB9 serial connector on the power cable should be connected to a computer’s line level serial port.



CAUTION: Reversing the polarity may cause damage to the ES-220R.

9.4 Example STOP/PAUSE Wiring Schematics

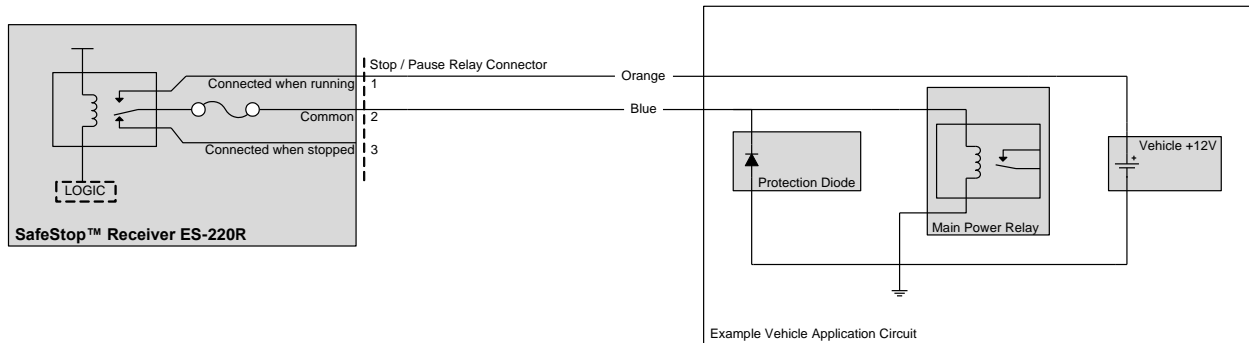

WARNING: When switching inductive loads such as relays, a protection diode should be used to suppress voltage transients.

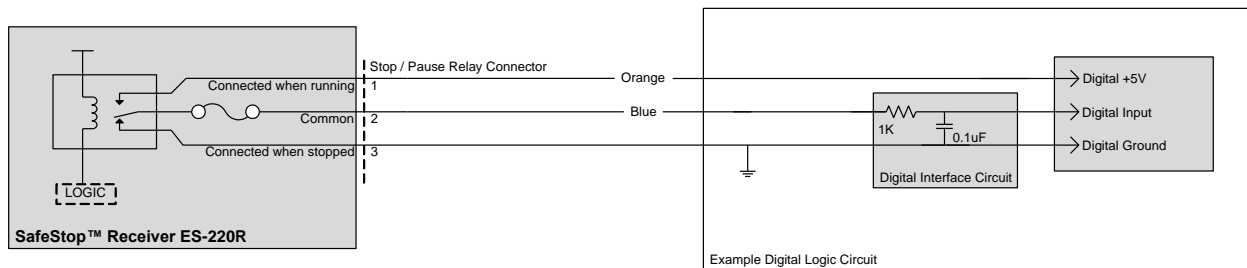

9.5 Example Latch/External Stop Wiring Schematics

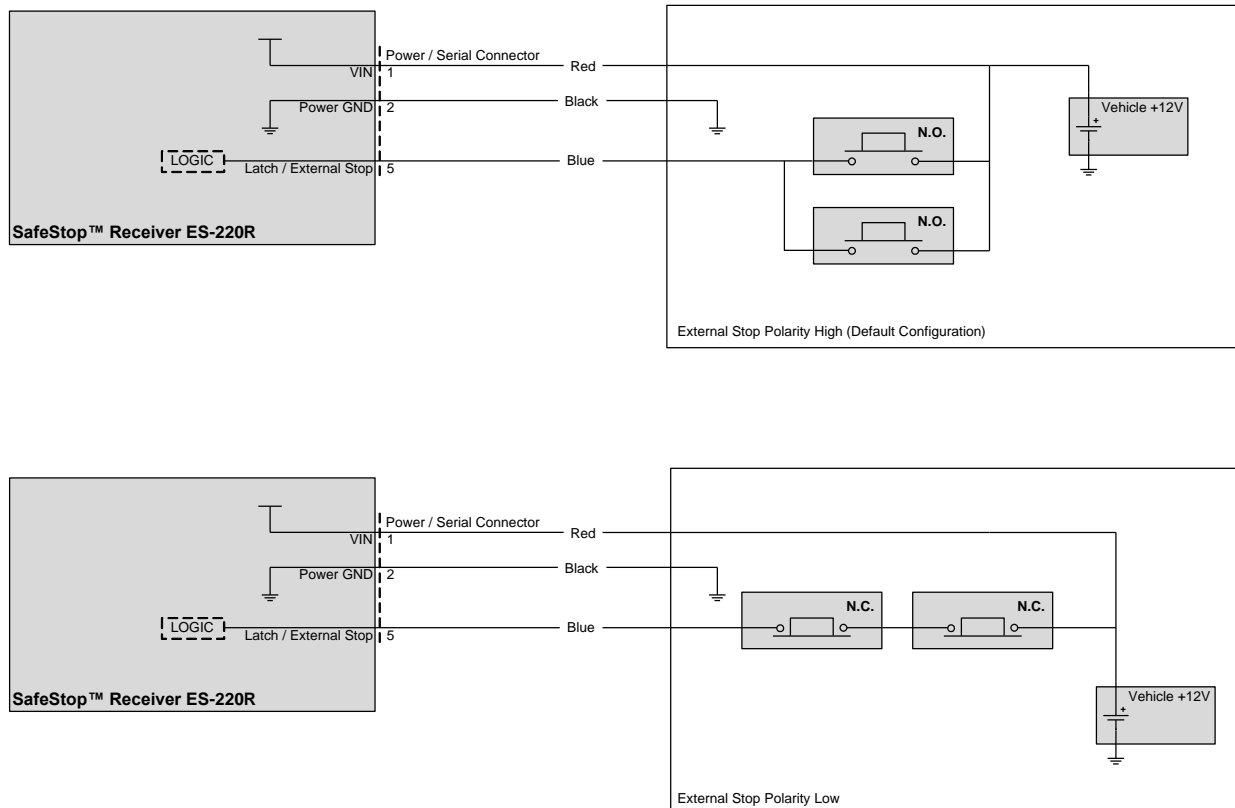

9.6 Verify Proper Operation of the System

After connecting the power cable to the ES-220R receiver, turn the power to the receiver on by switching the power switch to the up or “ON” position (the transmitter should not be powered at this time). Once power to the receiver is turned on, the “POWER” indicator should turn green after a brief self-test, indicating that this unit is powered on. The “LINK” indicator should turn red, indicating that there is no signal from the transmitter. The “PAUSE” and “STOP” indicators should also be red, indicating that both the Pause and Stop contacts are deactivated.

To verify the operation of the receiver and transmitter working together, turn the ES-220T transmitter power on while the receiver is still powered. Once power to the transmitter is turned on, the “POWER” indicator should be green signifying that it is powered on. The “LINK” indicator should turn green indicating that a communications link has been established between the transmitter and receiver. The “PAUSE” and “STOP” indicators should depict the state of the Pause switch and Stop button respectively. Changing the state of the Pause switch on the transmitter will change the state of the Pause contact on the receiver, which will switch the

“PAUSE” indicator accordingly. Likewise, pushing or releasing the Stop button will change the state of the Stop contact and update the “STOP” indicator.

Turning off power to the transmitter while the receiver is still powered will result in a loss of communications between the receiver and transmitter, resulting in the “LINK” indicator on the receiver to turn red, and the “PAUSE” and or “STOP” indicators to turn red depending on the preset timeout action.

Turning off power to the receiver while the transmitter is still powered will also result in a lost communications link and turn the “LINK” led on the transmitter red. Since there is no feedback from the receiver about the state of the contacts, both the “PAUSE” indicator and the “STOP” indicator will turn off. Upon a loss of link, the transmitter will also emit a constant tone indicating that the link to the receiver has been lost.

Switching the receiver Power/Bypass switch to the up or “BYPASS” position, overrides any signals being sent by the transmitter. In Bypass mode, the receiver “LINK” indicator will turn off to signify that the receiver is in Bypass mode. Also, both the Pause and Stop contacts will be activated, resulting in the “PAUSE” and “STOP” indicators to turn green. In Bypass mode, the receiver ignores all commands sent from the transmitter, and it is not possible to Stop or Pause a vehicle from the transmitter.



WARNING: It is not possible to stop or pause a vehicle from the transmitter when the receiver is placed in Bypass mode.

10 PHYSICAL DIMENSIONS

10.1 ES-220T Transmitter Dimensions

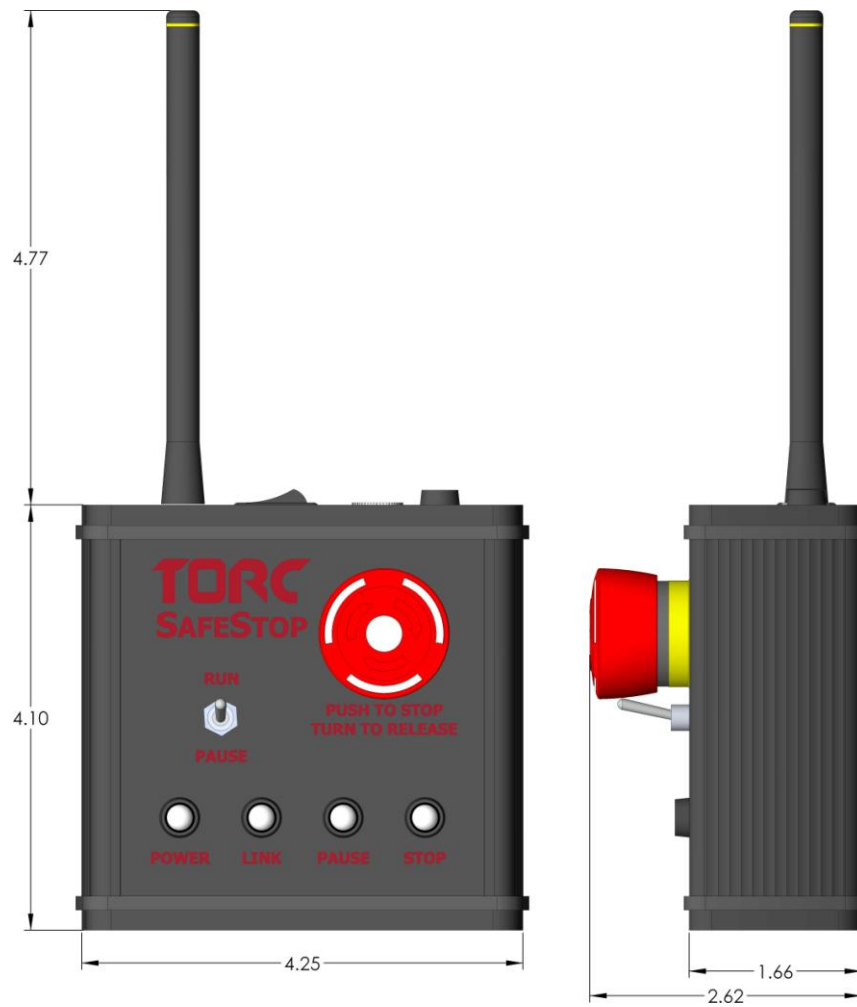

All units in inches.

10.2 ES-220R Receiver Dimensions

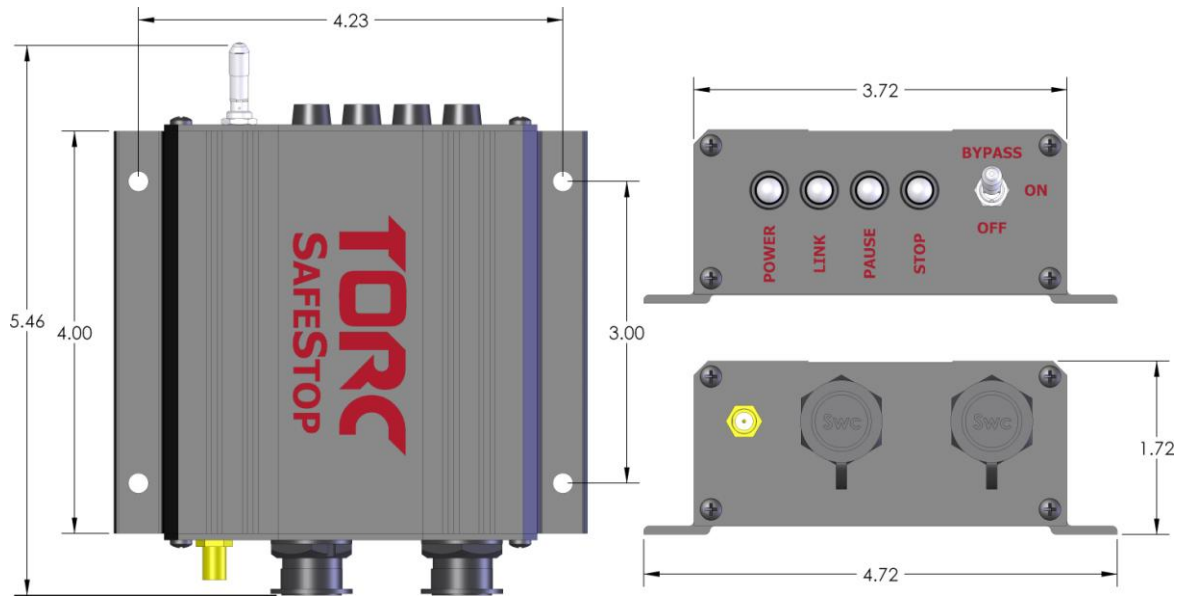

All units in inches.

10.3 Receiver Mounting Template

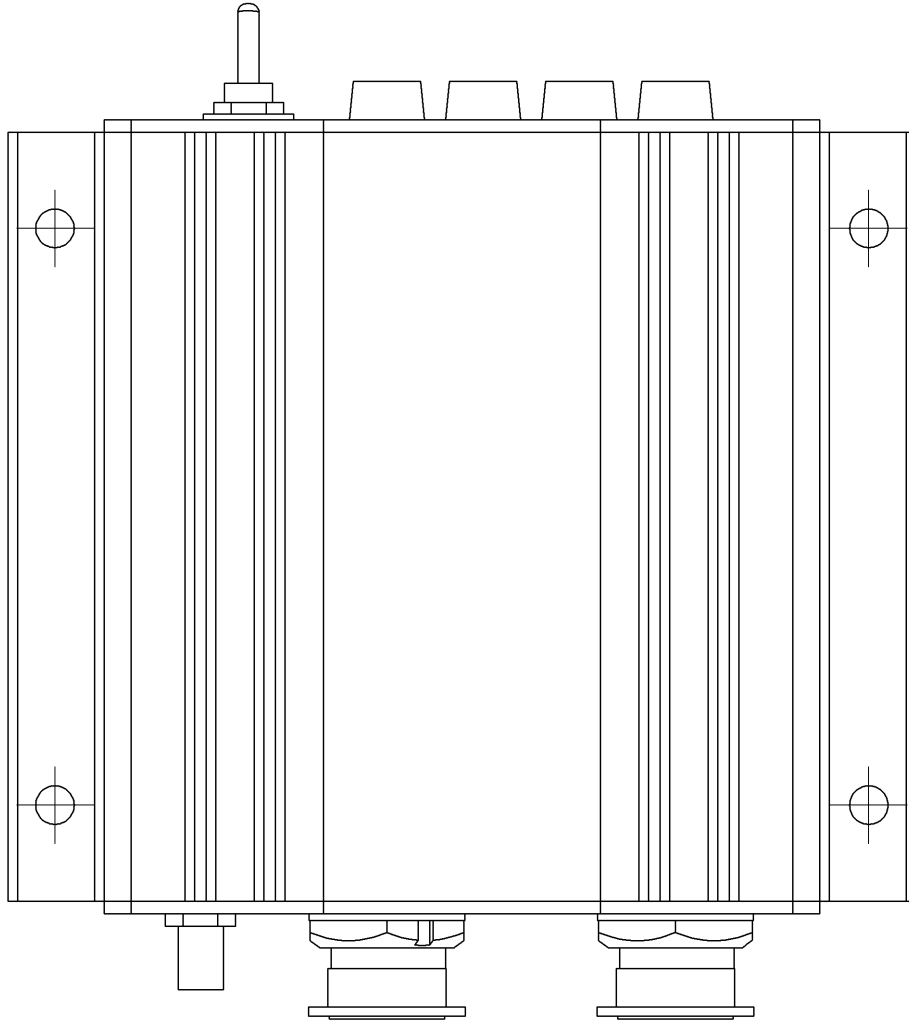

Scale 1:1 Use for mounting hole location

11 FCC COMPLIANCE

This equipment has been approved for mobile applications where the equipment should be used at distances greater than 20cm from the human body (with the exception of hands, wrists, feet, and ankles). Operation at distances less than 20 cm is strictly prohibited.

This device complies with Part 15 of the FCC Rules. Operation is subject to the following conditions: (1) This device may not cause harmful interference, and (2) This device must accept any interference received, including interference that may cause undesired operation.

FCC ID: KQL-AC4490

12 LIMITED WARRANTY

TORC Technologies, LLC (herein referred to as TORC) guarantees that the product(s) you have purchased from TORC are free from defects in materials or workmanship for a period of one year from the original date of purchase. Within this period TORC will, at its sole discretion, repair or replace any components which fail under normal use. This warranty does not cover failures due to abuse, misuse, accident, or unauthorized alterations or repairs.

There are no other warranties, expressed or implied, which extend beyond the description contained herein including the implied warranty of merchantability and fitness for a particular purpose. TORC expressly excludes all other warranties

TORC's liability is limited to the cost of repair or replacement of the product. Such remedy shall be the sole and exclusive remedy for any breach of warranty.

TORC shall not be liable for:

1. Damage to other property caused by any defects in the product, damages based upon inconvenience, loss of use of the product, loss of time, loss of profits, loss of business opportunity, loss of goodwill, interference with business relationships, or other commercial loss, even if advised of the possibility of such damages.
2. Any indirect or other damages, whether incidental, consequential, or otherwise.
3. Any claim against the customer by any other party.