

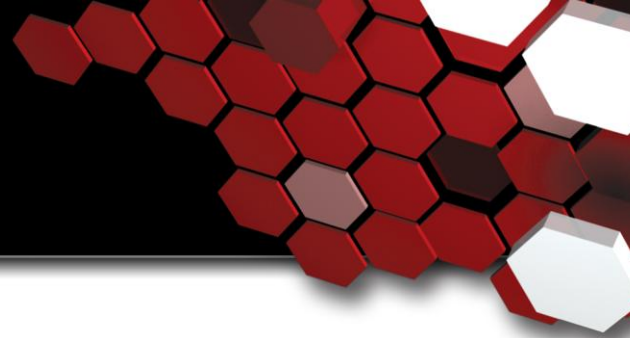

POWERHUB™

Power Distribution Module



User Manual

Intelligent Power Distribution

Single Unit



Web Configuration Utility

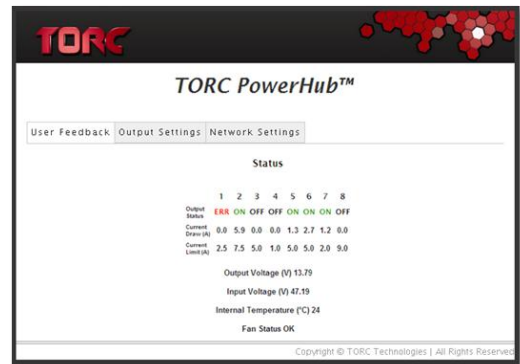

Rack Mounted Units



The PowerHub power distribution modules provide eight outputs at 5V, 12V or 24V, and are controlled over Ethernet for easy integration with unmanned and autonomous vehicle computer systems. The modules are capable of distributing up to 500W and are available in standalone or rackmount configurations.

TABLE OF CONTENTS

| | | |
|----------|---|-----------|
| 1 | ASSIGNMENT OF LIABILITY | 3 |
| 2 | GENERAL SAFETY INFORMATION | 4 |
| 3 | PACKAGE CONTENTS | 5 |
| 4 | POWERHUB OVERVIEW | 6 |
| 5 | POWERHUB SPECIFICATIONS | 7 |
| 5.1 | Electrical specifications | 7 |
| 5.2 | Interface / Contact Ratings..... | 11 |
| 5.3 | Visual Indicators..... | 11 |
| 5.4 | Environmental..... | 11 |
| 6 | WEB-BASED CONFIGURATION | 12 |
| 6.1 | The Status Tab..... | 12 |
| 6.2 | The Output Settings Tab..... | 14 |
| 6.3 | The Network Settings Tab | 15 |
| 7 | ADVANCED COMMUNICATION PROTOCOL | 16 |
| 7.1 | PuTTY configuration | 17 |
| 8 | POWERHUB DETAIL | 19 |
| 8.1 | Front View..... | 19 |
| 8.2 | Rear View..... | 20 |
| 8.3 | Connector Pinouts..... | 21 |
| 8.4 | Remote Enable Connection | 23 |
| 9 | PHYSICAL DIMENSIONS AND MOUNTING | 23 |

9.1 Rack mount Faceplate Dimensions 24

9.2 Standalone Mounting Configuration 26

10 LIMITED WARRANTY 27

1 ASSIGNMENT OF LIABILITY

WARNING: DO NOT OPERATE UNTIL USER MANUAL IS REVIEWED AND UNDERSTOOD. PRODUCT USE IS SUBJECT TO STRICT TERMS AND CONDITIONS. SEE CUSTOMER AGREEMENT FOR ADDITIONAL USE RESTRICTIONS. OPERATING PRODUCT IN VIOLATION OF USER RESTRICTIONS COULD RESULT IN PRODUCT MALFUNCTION, PROPERTY DAMAGE, AND PERSONAL INJURY INCLUDING DEATH.

NOTICE: USER ASSUMES ALL RISKS ASSOCIATED WITH POSSESSION OR USE OF PRODUCT AND RELATED SYSTEMS. USER AGREES TO INDEMNIFY, DEFEND AND HOLD HARMLESS TORC FROM ANY DAMAGES ARISING OUT OF POSSESSION OR USE OF PRODUCT AND RELATED SYSTEMS. TORC IS NOT LIABLE FOR ANY DAMAGES OF ANY KIND.

GENERAL SAFETY INFORMATION

The following symbols are used throughout the user manual to indicate a particularly hazardous condition.



WARNING: Indicates a hazardous condition that could result in serious injury or loss of life if not performed properly.



CAUTION: Indicates a hazardous condition or procedure that could result in damage to this product, or loss related to equipment malfunction.



NOTE: A note indicates information that may not be applicable regarding system safety but needs to be known for best system performance.

Read this manual before using the PowerHub.

Make sure to read this manual in its entirety before using the PowerHub. Failure to follow the instructions and warnings contained in this manual could result in damage to the unit or the external devices it is connected to.

Do Not Operate With Suspected Failures.

If you suspect there is damage to the product, contact TORC Technologies to have it inspected before further use.

Do Not Attempt to Modify or Disassemble.

To avoid shock hazard and/or damage to the product, do not attempt to open the case, make modifications, or repair the device. Opening, modifying or repairing this device will void any applicable warranty and could prevent the device from operating properly.

Do Not Operate in Wet/Damp Conditions.

To avoid shock hazard and/or product malfunction, do not operate in a wet or damp environment.

2 PACKAGE CONTENTS

After unpacking the contents of the PowerHub system, please verify the contents of the package includes the following items:

- PowerHub™ Module with Faceplate
- Network Cable
- User Manual
- Starter Kit
 - Remote Enable Jumper
 - Input Connector and Pins
 - Output Cables (x4) (single output cable displayed)
- Mounting Bracket (Standalone Only)



Figure 1: PowerHub Package Contents (standalone faceplate with optional mounting bracket)

3 POWERHUB OVERVIEW

The TORC PowerHub provides computer controlled power distribution designed for applications in unmanned systems. The PowerHub is available with a 12V, 24V, or 48V nominal input, and a 5V, 12V, or 24V nominal output. Convenient control over Ethernet allows each of the 8 outputs to be switched and monitored remotely. An intuitive web interface allows the user to directly configure and use the PowerHub during testing and development. In addition, a simple TCP protocol allows for advanced computer control. The PowerHub provides unmanned systems developers with a compact and highly functional power conditioning and distribution solution, allowing them to focus on more complex design and control tasks.

4 POWERHUB SPECIFICATIONS

4.1 Electrical specifications

PH482401

| Parameter | Min | Typ | Max | Unit | Notes |
|----------------------------|------|-------|------|------|--------------------------------|
| Operating input voltage | 36 | 48 | 60 | Vdc | |
| Adjusted output voltage | 19.2 | 24 | 26.4 | Vdc | nominal input; full load; 25°C |
| Output Power | | | 500 | W | nominal input; 24VDC output |
| Output ripple | | 75 | | mV | p-p; nominal input; full load |
| Load regulation | | ±0.02 | ±0.2 | % | nominal input; no load to full |
| Efficiency | | 85 | | % | nominal input; full load; 25°C |
| Disabled power consumption | | 0.05 | | W | remote disable |
| Enabled power consumption | | 1.3 | | W | outputs off, no load |
| | | 13.3 | | W | outputs on, no load |

PH481201

| Parameter | Min | Typ | Max | Unit | Notes |
|----------------------------|------|-------|------|------|--------------------------------|
| Operating input voltage | 36 | 48 | 60 | Vdc | |
| Adjusted output voltage | 10.5 | 12 | 16.5 | Vdc | nominal input; full load; 25°C |
| Output Power | | | 400 | W | nominal input; 12VDC output |
| Output ripple | | 85 | | mV | p-p; nominal input; full load |
| Load regulation | | ±0.02 | ±0.2 | % | nominal input; no load to full |
| Efficiency | | 87 | | % | nominal input; full load; 25°C |
| Disabled power consumption | | 0.05 | | W | remote disable |
| Enabled power consumption | | 1.3 | | W | outputs off, no load |
| | | 15.3 | | W | outputs on, no load |

PH480501

| Parameter | Min | Typ | Max | Unit | Notes |
|----------------------------|-----|-------|------|------|--------------------------------|
| Operating input voltage | 36 | 48 | 60 | Vdc | |
| Adjusted output voltage | 4.5 | 5 | 5.5 | Vdc | nominal input; full load; 25°C |
| Output Power | | | 400 | W | nominal input; 12VDC output |
| Output ripple | | 80 | | mV | p-p; nominal input; full load |
| Load regulation | | ±0.02 | ±0.2 | % | nominal input; no load to full |
| Efficiency | | 82 | | % | nominal input; full load; 25°C |
| Disabled power consumption | | 0.05 | | W | remote disable |
| Enabled power consumption | | 1.3 | | W | outputs off, no load |
| | | 12.6 | | W | outputs on, no load |

PH242401

| Parameter | Min | Typ | Max | Unit | Notes |
|----------------------------|------|-------|------|------|--------------------------------|
| Operating input voltage | 18 | 24 | 36 | Vdc | |
| Adjusted output voltage | 19.2 | 24 | 26.4 | Vdc | nominal input; full load; 25°C |
| Output Power | | | 400 | W | nominal input; 24VDC output |
| Output ripple | | 80 | | mV | p-p; nominal input; full load |
| Load regulation | | ±0.02 | ±0.2 | % | nominal input; no load to full |
| Efficiency | | 86 | | % | nominal input; full load; 25°C |
| Disabled power consumption | | 0.05 | | W | remote disable |
| Enabled power consumption | | 1.3 | | W | outputs off, no load |
| | | 16.3 | | W | outputs on, no load |

PH241201

| Parameter | Min | Typ | Max | Unit | Notes |
|----------------------------|------|-------|------|------|--------------------------------|
| Operating input voltage | 18 | 24 | 36 | Vdc | |
| Adjusted output voltage | 10.5 | 12 | 16.5 | Vdc | nominal input; full load; 25°C |
| Output Power | | | 320 | W | nominal input; 12VDC output |
| Output ripple | | 160 | | mV | p-p; nominal input; full load |
| Load regulation | | ±0.02 | ±0.2 | % | nominal input; no load to full |
| Efficiency | | 85 | | % | nominal input; full load; 25°C |
| Disabled power consumption | | 0.05 | | W | remote disable |
| Enabled power consumption | | 1.3 | | W | outputs off, no load |
| | | 11.6 | | W | outputs on, no load |

PH240501

| Parameter | Min | Typ | Max | Unit | Notes |
|----------------------------|-----|-------|------|------|--------------------------------|
| Operating input voltage | 18 | 24 | 36 | Vdc | |
| Adjusted output voltage | 4.5 | 5 | 5.5 | Vdc | nominal input; full load; 25°C |
| Output Power | | | 400 | W | nominal input; 5VDC output |
| Output ripple | | 152 | | mV | p-p; nominal input; full load |
| Load regulation | | ±0.02 | ±0.2 | % | nominal input; no load to full |
| Efficiency | | 80 | | % | nominal input; full load; 25°C |
| Disabled power consumption | | 0.05 | | W | remote disable |
| Enabled power consumption | | 1.3 | | W | outputs off, no load |
| | | 12.5 | | W | outputs on, no load |

PH122401

| Parameter | Min | Typ | Max | Unit | Notes |
|----------------------------|------|-------|------|------|--------------------------------|
| Operating input voltage | 10 | 24 | 36 | Vdc | |
| Adjusted output voltage | 19.2 | 24 | 26.4 | Vdc | nominal input; full load; 25°C |
| Output Power | | | 200 | W | nominal input; 24VDC output |
| Output ripple | | 315 | | mV | p-p; nominal input; full load |
| Load regulation | | ±0.02 | ±0.2 | % | nominal input; no load to full |
| Efficiency | | 82 | | % | nominal input; full load; 25°C |
| Disabled power consumption | | 0.05 | | W | remote disable |
| Enabled power consumption | | 1.3 | | W | outputs off, no load |
| | | 17.6 | | W | outputs on, no load |

PH121201

| Parameter | Min | Typ | Max | Unit | Notes |
|----------------------------|------|-------|------|------|--------------------------------|
| Operating input voltage | 10 | 24 | 36 | Vdc | |
| Adjusted output voltage | 10.5 | 12 | 16.5 | Vdc | nominal input; full load; 25°C |
| Output Power | | | 160 | W | nominal input; 12VDC output |
| Output ripple | | 220 | | mV | p-p; nominal input; full load |
| Load regulation | | ±0.02 | ±0.2 | % | nominal input; no load to full |
| Efficiency | | 81 | | % | nominal input; full load; 25°C |
| Disabled power consumption | | 0.05 | | W | remote disable |
| Enabled power consumption | | 1.3 | | W | outputs off, no load |
| | | 18 | | W | outputs on, no load |

PH120501

| Parameter | Min | Typ | Max | Unit | Notes |
|----------------------------|-----|-------|------|------|--------------------------------|
| Operating input voltage | 10 | 24 | 36 | Vdc | |
| Adjusted output voltage | 4.5 | 5 | 5.5 | Vdc | nominal input; full load; 25°C |
| Output Power | | | 175 | W | nominal input; 5VDC output |
| Output ripple | | 280 | | mV | p-p; nominal input; full load |
| Load regulation | | ±0.02 | ±0.2 | % | nominal input; no load to full |
| Efficiency | | 74 | | % | nominal input; full load; 25°C |
| Disabled power consumption | | 0.05 | | W | remote disable |
| Enabled power consumption | | 1.3 | | W | outputs off, no load |
| | | 19.7 | | W | outputs on, no load |

CONTROL AND SENSING

| Parameter | Min | Typ | Max | Unit | Notes |
|----------------------------|-----|-----|-----|-------|-------------------------|
| Current limit accuracy | | 0.5 | | A | 25 deg C |
| Voltage set point accuracy | | ±2 | ±5 | % | of nominal output |
| Temperature accuracy | | ±1 | | deg C | |
| Output fault shutoff time | | | 2 | ms | Output shorted |
| Aux supply output current | | | 500 | mA | |
| Remote enable logic high | 2 | | 60 | V | Internal 100k pull-down |
| Remote enable logic low | | | 0.8 | V | Internal 100k pull-down |

OUTPUT DERATING

The PowerHub is both current limited and power limited. When operating below the nominal output voltage, the current is constant and the maximum output power is reduced. When operating above the nominal output voltage, the power is constant and the maximum output current is reduced. Exceeding the PowerHub output ratings will cause it to not function properly until corrected. Refer to Figure 2 for operation outside the nominal output voltage.

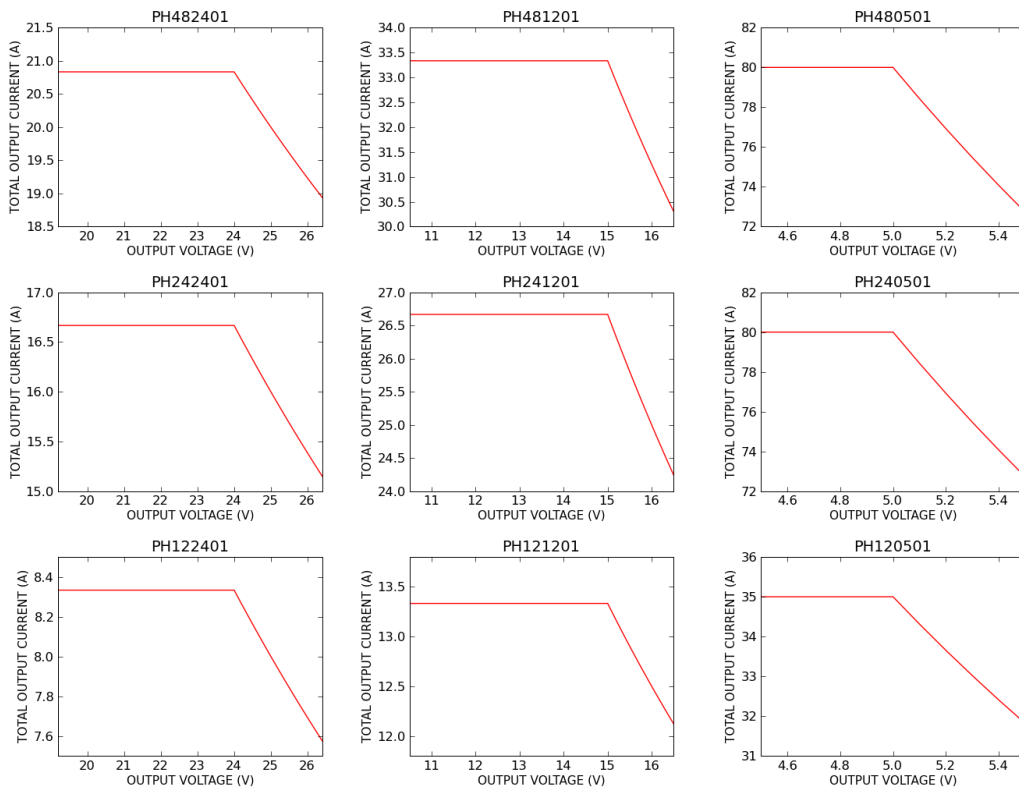

Figure 2: PowerHub Output Derating Curves

4.2 Interface / Contact Ratings

INPUT CONNECTION

| | |
|------------------------|------------------|
| Connector Part Number: | Molex 42820-2212 |
| Mating Part Number: | Molex 42816-0212 |
| Max Current: | 48.0 Amps |

OUTPUT CONNECTIONS

| | |
|-------------------------|------------------|
| Connector Part Number: | Molex 39-30-1022 |
| Mating Part Number: | Molex 39-01-3028 |
| Max Current Per Output: | 9.0 Amps |

REMOTE ENABLE CONNECTION

| | |
|------------------------|------------------|
| Connector Part Number: | Molex 43650-0303 |
| Mating Part Number: | Molex 43645-0300 |
| Max Current: | 5.0 Amps |

ETHERNET CONNECTION

Standard RJ-45 jack, supporting CAT5, CAT5e, and CAT6 network cables

SERIAL DATA CONNECTION

Standard female DE-9 jack, RS-232 serial communication

4.3 Visual Indicators

| | |
|---------------------------|---|
| Output Status Indication: | Bicolor LEDs, GREEN – output on RED – overcurrent fault |
|---------------------------|---|

4.4 Environmental

| | |
|---------------------------|---------------------------|
| Operational Temperature: | -20°C to 60°C |
| Operational Humidity: | 5% to 90%, non-condensing |
| Operational Shock Rating: | 98 m/s ² |

5 WEB-BASED CONFIGURATION

All settings on the PowerHub can be controlled through the web-based configuration utility. To access the utility, launch a web browser on a computer that is connected to the PowerHub and enter the PowerHub IP address into the address field. The factory default IP address is **192.168.0.150**. If the IP address is forgotten, refer to section 8.2 for instructions on how to reset the factory defaults.

5.1 The Status Tab

When the configuration page is loaded, the status tab will be displayed as shown below in Figure 3. The status tab displays the current state of each output, the measured input and output voltages, the internal temperature of the unit, and the fan status. This page is configured to automatically refresh once every two seconds.

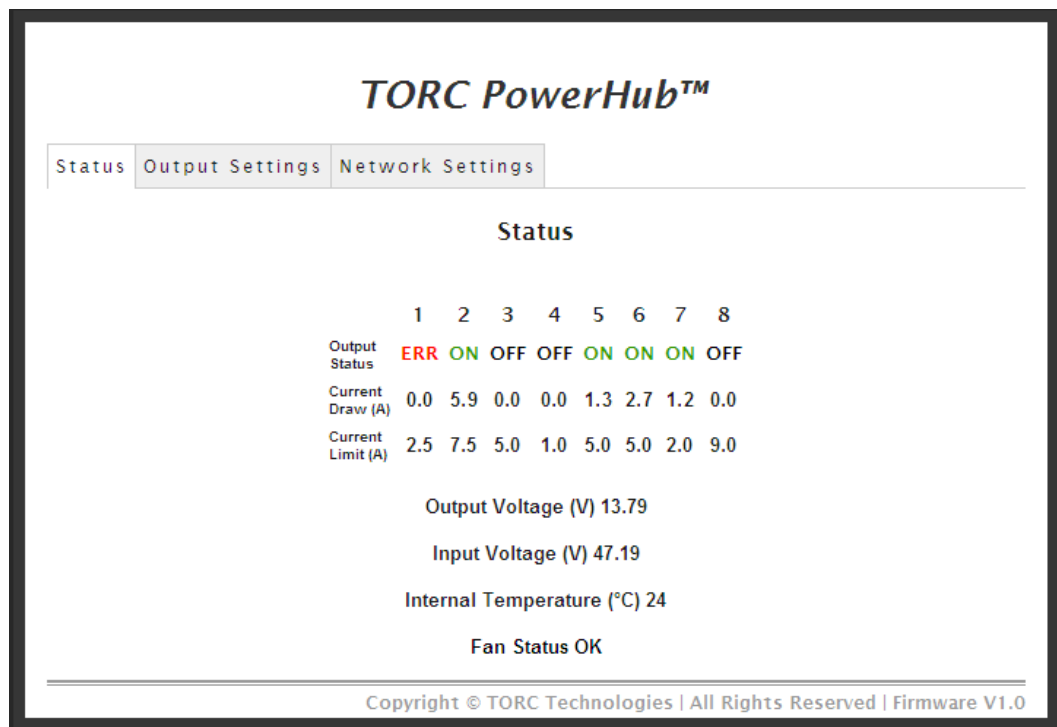

Figure 3: The status tab of the web based configuration utility.

The output status reflects the current state of each output. The possible states are **ON**, **OFF**, and **ERR**. When the output is set to the **ON** state, the positive output terminal is connected to the output voltage via a solid state relay. In the **OFF** and **ERR** states, the positive output terminal is disconnected from the output voltage and left floating.

The current draw and fault current limit for each output is displayed with 100mA resolution. The fault current limit can be used as a software configurable fuse to ensure that if a particular output draws higher current than expected, the output is disabled. This prevents one malfunctioning device from overloading the PowerHub and causing all outputs to be current limited.

The PowerHub output and input voltages are measured internally and displayed with 10mV resolution. These voltages are displayed as a reference, confirming the current state of the module.

The internal temperature of the PowerHub corresponds to the exhaust air temperature and is provided with 1°C resolution. If the internal temperature of the PowerHub is too high, the module will shutdown. To resume operation the input power must be cycled using the Master power switch on the front panel or by the remote enable connection.

Finally, the fan status is displayed as **OK** if the fans are operating as expected and **ERR** if one or both of the cooling fans have stalled. The fan status is only a warning to the user and the outputs will remain active until the module overheats. If a fan error is detected, the maximum operational temperature of the PowerHub will be reduced until the error is cleared.

5.2 The Output Settings Tab

The output settings tab provides the interface to control the function of the PowerHub. The user can turn outputs **ON** or **OFF**, set the current limit, and adjust the desired output voltage. Figure 4 displays the output settings tab.

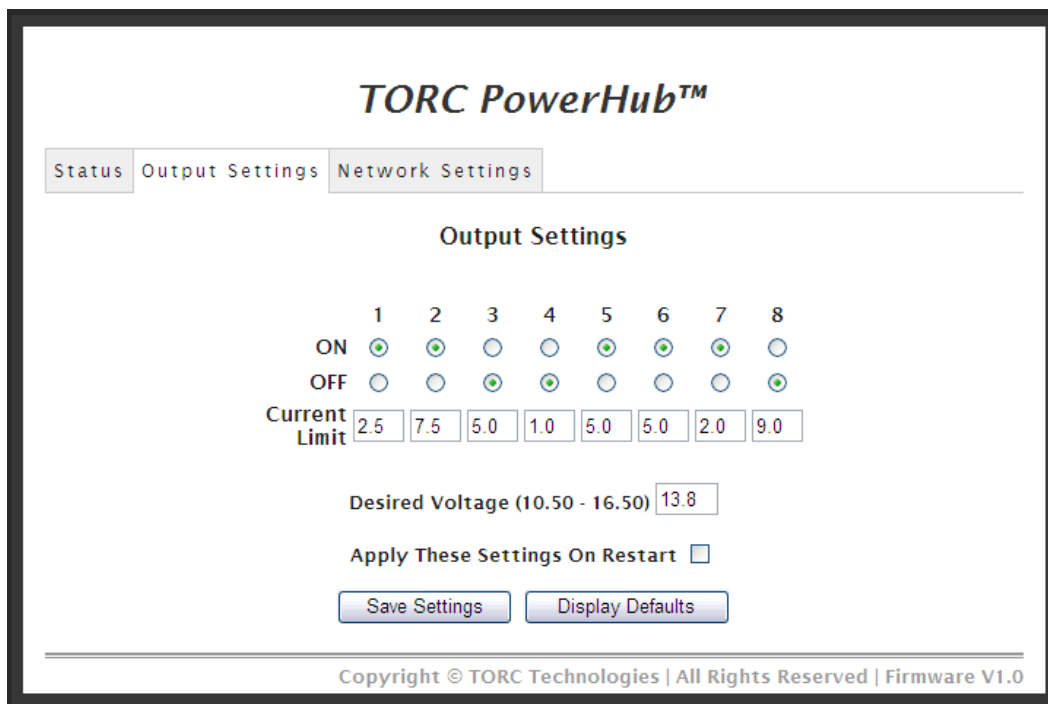

Figure 4: The Output Settings tab of the PowerHub Configuration menu.

After the output settings page is loaded, the **ON** and **OFF** radio buttons reflect the current state of each output. Clicking on the radio buttons for each output will command an on or off state. If an output fault has occurred, the output state will be displayed as **OFF** and the error can be reset by selecting the **ON** radio button for that channel. Settings will be applied only when the “Save Settings” button is selected.

Current limits can be adjusted by typing the desired value in the text box. The current limit may be entered with a 100mA resolution from 0.0 to 9.0A per channel.

Each of the 5V, 12V, and 24V PowerHub units allow the output voltage to be adjusted around the nominal output voltage of the module. The range of acceptable voltages is displayed in parenthesis next to the text box where it is entered.

The PowerHub settings can be saved in two ways: default settings or current operation settings. If saved as default settings, the saved settings will be the power-up configuration of the PowerHub. Current operation settings, on the other hand, will be lost when the PowerHub is turned off. To save the output settings as default, select the “Apply These Settings on Restart” checkbox before saving the changes.

Pressing the “Save Settings” button will apply the output settings selection. If the user navigates to another tab before saving, the changes will not applied.

When the “Display Defaults” button is pressed, the current power-up configuration is displayed.

5.3 The Network Settings Tab

The PowerHub can be configured to be accessed as a part of any network by changing the configurations on the Network Settings tab of the PowerHub configuration menu. The factory defaults are:

- IP Address: **192.168.0.150**
- Subnet Mask: **255.255.255.0**
- Gateway: disabled (**0.0.0.0**)

TORC PowerHub™

Status Output Settings **Network Settings**

Network Settings

IP Address

Subnet Mask

Default Gateway

Copyright © TORC Technologies | All Rights Reserved | Firmware v1.2b

Figure 5: The Network Settings configuration tab.

6 ADVANCED COMMUNICATION PROTOCOL

In addition to the web interface, the PowerHub also accepts ASCII commands over TCP (firmware v1.1 and above). The commands are made up of a command word and one or more arguments separated by spaces. A carriage return (0x0D) followed by a new line (0x0A) denotes the end of each complete command and terminates each response. Only NVT ASCII characters are valid, and any telnet option requests will trigger a WONT or DONT response (See RFC 854 for details). This permits the use of either a standard telnet client or a raw TCP connection to port 23.

The serial port may also be used for sending and receiving advanced communications protocol messages (firmware v1.2 and above). It is configured for 115200 baud, 8 data bits, no parity, 1 stop bit, and no flow control.

The following commands are available:

ON - Switches an output to the **ON** state.

Usage: "ON <output numbers, separated by spaces>\r\n"

Example: "ON ALL\r\n" will turn all outputs on

Example: "ON 1 8 4\r\n" will turn outputs 1, 8, and 4 on.

OFF - Switches an output to the **OFF** state

Usage: "OFF <output numbers, separated by spaces>\r\n"

Example: "OFF ALL" will turn all outputs off

Example: "OFF 1 5 3\r\n" will turn outputs 1, 5, and 3 off.

STATUS - Displays system status

Usage: "STATUS <option>\r\n"

Options:

OUT – Current output state

Example: "STATUS OUT\r\n"

could return "OUT ON OFF OFF ERR ON ON OFF OFF\r\n"

IOUT – Current output amperes

Example: "STATUS IOUT\r\n"

could return "IOUT 1.2 0.0 0.0 0.0 8.5 0.1 0.0 0.0\r\n"

VOUT – Current output voltage

Example: "STATUS VOUT\r\n" could return "VOUT 13.8\r\n"

VIN – Current input voltage.

Example: "STATUS VIN\r\n" could return "VIN 55.0\r\n"

FAN – Current fan state

Example: "STATUS FAN\r\n" could return "FAN OK\r\n" or "FAN ERR\r\n"

TEMP – Current temperature in degrees Celsius

Example: “STATUS TEMP\r\n” could return “TEMP 25\r\n”

IP – Current IP address

Example: “STATUS IP\r\n” could return “IP 192.168.0.150\r\n”

PowerHub configuration options such as current limits, desired voltage, and network settings are currently only accessible using the web-based configuration utility.

The freely available telnet/ssh client, “PuTTY” can be used to test the PowerHub advanced communication protocol. The necessary setup required to use the PuTTY client is outlined in the following section.

6.1 PuTTY configuration

To configure the PuTTY telnet client for testing the PowerHub advanced communication protocol, follow the steps outlined below.

In the “Session” menu, enter the IP address of the PowerHub and select the “Telnet” connection type (will auto-fill Port 23), shown in Figure 6. If desired, these settings can be saved for future use by clicking the “Save” button. Once configured, click the “Open” button to create a TCP connection to the PowerHub.

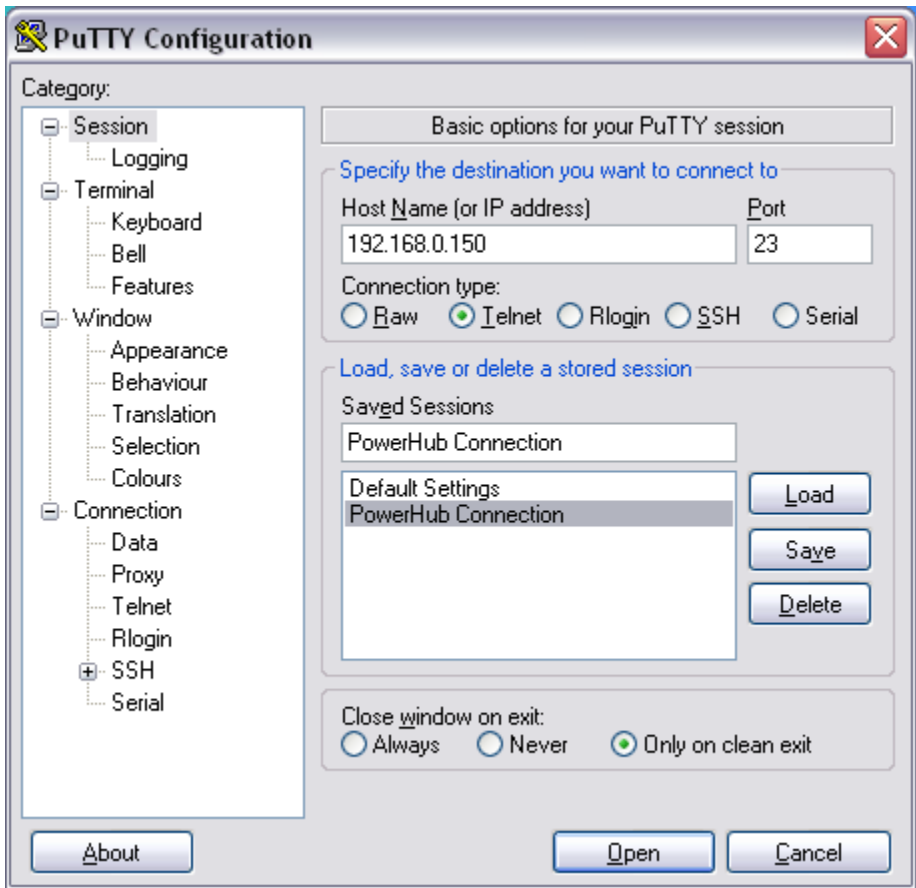

Figure 6: The session tab of the PuTTY configuration menu.

Commands can now be entered into the PuTTY console, validating the PowerHub control over the TCP communications protocol. A screenshot from an example PuTTY session is included as Figure 7.



Figure 7: An example using PuTTY to control the PowerHub.

7 POWERHUB DETAIL

7.1 Front View

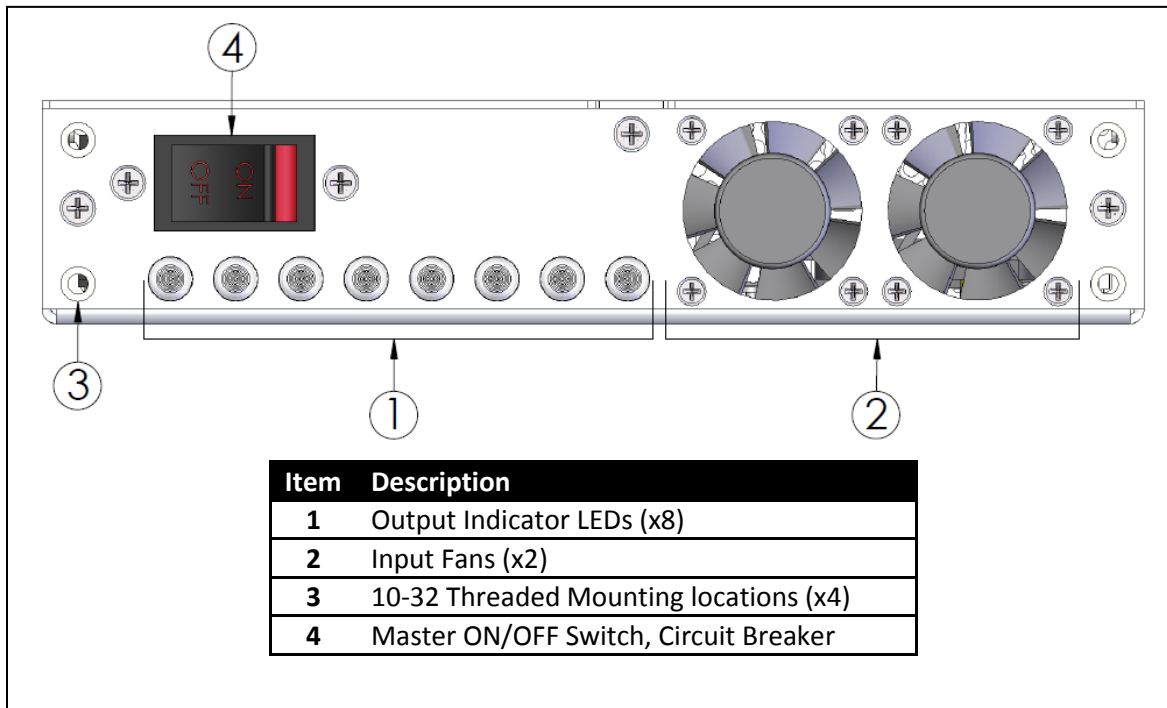

Figure 8: Front View of the PowerHub

On the front face of the PowerHub, there are indicator LEDs (1) for each of the eight outputs. These LEDs will illuminate GREEN when the corresponding output is enabled and RED if an overcurrent fault is detected on the output. If the LED is off, the output is **OFF**. The left most LED corresponds to output one and the right most LED corresponds to output eight.

The two fans (2) provide forced air cooling of the internal electronics and are turned on automatically anytime an output is active. Internal fan speed monitoring ensures both fans are functioning properly. The direction of air flow through the PowerHub is from front to rear.

Four mounting holes (3) on the face of the PowerHub are the primary method of attaching the device mounting brackets. These holes are threaded for a 10-32 machine screw.

The rocker switch (4) on the front of the PowerHub serves as a dual purpose as the Master ON/OFF switch and a resettable circuit breaker. This breaker interrupts all input current to the PowerHub, protecting against a short circuit condition. With the Master Switch in the ON position, the PowerHub is powered and outputs are under software control via the Ethernet interface. If the Master Switch is in the OFF position, the PowerHub is disabled and in a zero power mode.

7.2 Rear View

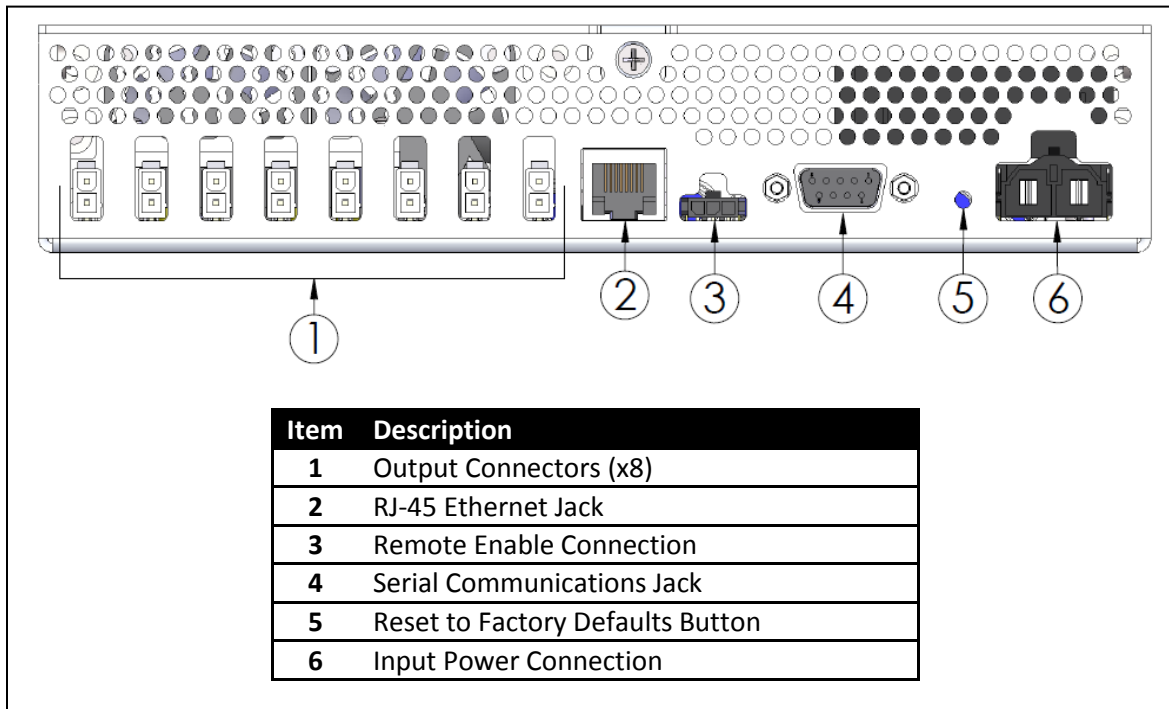

Figure 9: Rear View of PowerHub

All connections to the PowerHub are located on the rear of the unit. The output connectors (1) are numbered right to left, one through eight. The output connectors are Molex part number 39-30-1022 and the mating plug is Molex part number 39-01-3028. The output ground, input ground, and chassis are all connected internally.

The Ethernet jack (2) is an RJ-45 connector located next to the output connectors. The network interface is a 10/100 Mbps auto-sensing connection.

The remote enable connection (3) allows the PowerHub to be enabled and disabled via external circuitry (e.g. a vehicle key switch). When disabled, the PowerHub will operate in a very low power state. If the remote enable capability is not required, a jumper can be used to connect pins one and three, configuring the PowerHub to always be enabled when the Master Switch is in the ON position. Refer to Section 7.4 for additional information on the remote enable feature.



CAUTION: Pin 1 on the Remote Enable connector is tied to the input voltage. Ensure any external circuitry connected to this pin is rated for the input voltage of the unit.

The serial communications jack (4) is a female 9 pin D-subminiature connector. This port is used for firmware updates as well as the advanced communication protocol messages.

A reset to factory defaults button (5) can be pressed using a paperclip or other small object. Holding this button until a beep is heard (approximately 5 seconds) will reset all configuration settings to the factory defaults. Once the button is released, the PowerHub will reset to apply the settings.

The input power connector (6) is a Molex 42820-2212 connector. The mating plug is Molex part number 42816-0212. Pin 1 is positive input and Pin 2 is ground.

7.3 Connector Pinouts

INPUT CONNECTION

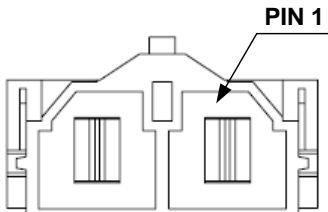
|  | PIN # | DESCRIPTION |
|---|-------|------------------------------------|
| | 1 | V_{IN}^+ Positive input terminal |
| | 2 | GND Negative input terminal |

OUTPUT CONNECTIONS

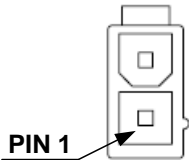
|  | PIN # | DESCRIPTION |
|---|-------|--------------------------------------|
| | 1 | V_{OUT}^+ Positive output terminal |
| | 2 | GND Negative output terminal |

REMOTE ENABLE CONNECTION

| | PIN # | DESCRIPTION |
|--|-------|--|
| | 1 | V _{REF} Positive output terminal = V _{IN} ⁺ |
| | 2 | GND Negative output terminal |
| | 3 | SIG Remote Enable Input (5-60V) |

ETHERNET CONNECTION

| | PIN # | DESCRIPTION |
|--|-------|--------------------------------|
| | 1 | TXD + Ethernet Transmit Data + |
| | 2 | TXD - Ethernet Transmit Data - |
| | 3 | RXD + Ethernet Receive Data + |
| | 6 | RXD - Ethernet Receive Data - |

RS-232 CONNECTION

| | PIN # | DESCRIPTION |
|--|-------|-----------------------------------|
| | 2 | TXD RS-232 Transmit Data (To PC) |
| | 3 | RXD RS-232 Receive Data (From PC) |
| | 5 | GND RS-232 Signal ground |

7.4 Remote Enable Connection

The remote enable connection is used to transition the PowerHub from a low power disabled state to an active state. To enable the PowerHub, this input needs to be connected to a voltage between 2-60 Vdc in reference to ground (Pin 2 of the Remote Enable Connector). When left disconnected, the PowerHub is in the disabled state. When the PowerHub is disabled, all outputs and communications are inactive.



CAUTION: Pin 1 on the Remote Enable connector is fused internally. Always keep any load on this connector safely below 500 mA.



CAUTION: Pin 1 on the Remote Enable connector is tied to the input voltage. Ensure any external circuitry connected to this pin is rated for the input voltage of the unit.

EXAMPLE CONFIGURATION



Figure 10: Remote enable configuration example – vehicle key switch

The accessory line of a vehicle key switch can be used as a convenient remote enable input to the PowerHub. In this configuration, the PowerHub is enabled when the key is in the ACC position and disabled when the vehicle is turned off.

JUMPER CONFIGURATION

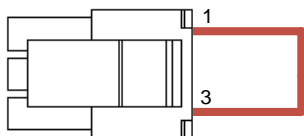

Figure 11: Remote Enable Jumper

A remote enable jumper is included with the PowerHub. When the jumper is in place, the PowerHub will auto-enable any time power is supplied to the input connector. The PowerHub will not go into low power state with the jumper installed.

8 PHYSICAL DIMENSIONS AND MOUNTING

The slim form factor of the PowerHub Series of managed power distribution modules provides a compact solution that is easily integrated into new or existing designs. A dimensioned outline drawing of the PowerHub is included as Figure 12.

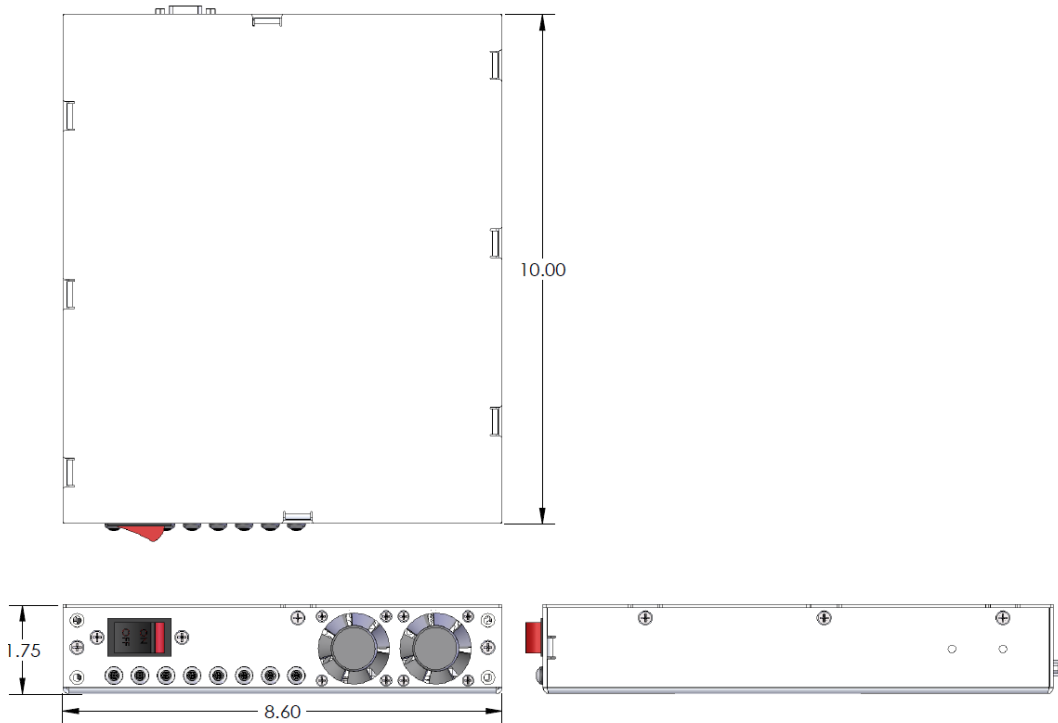

Figure 12: The physical dimensions of the base PowerHub module.

The PowerHub is designed to be mounted using one of several faceplate mounting options. Faceplates are available for side-by-side rack mount, single rack mount, and standalone configurations. Figure 13 shows the PowerHub in each one of these mounting arrangements. The side-by-side rack mount option allows two PowerHub devices to occupy just one unit of space in a standard 19 inch computing rack. If an odd number of PowerHub units are desired, a single PowerHub faceplate is available which also occupies one unit in a 19 inch rack. Finally, if a rack mount configuration is not desired, a standalone mounting kit is available.

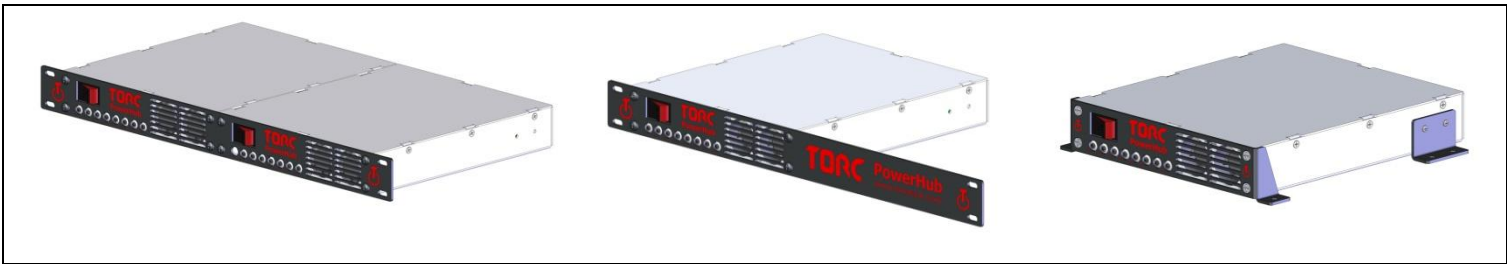

Figure 13: The PowerHub shown with different mounting options.

8.1 Rack mount Faceplate Dimensions

The rack mount faceplates are designed to occupy one unit of a standard 19 inch computer rack. Dimensioned drawings of the rack mount faceplate options are included in Figure 14 and 15.

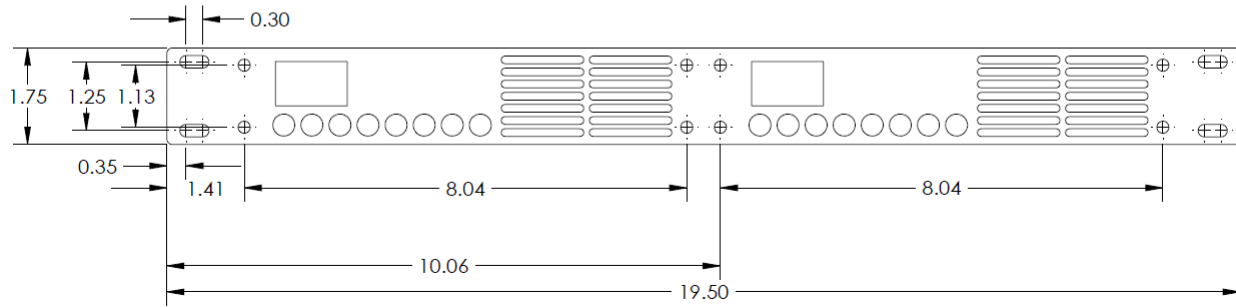

Figure 14: Dimensioned side-by-side rack mount faceplate drawing.

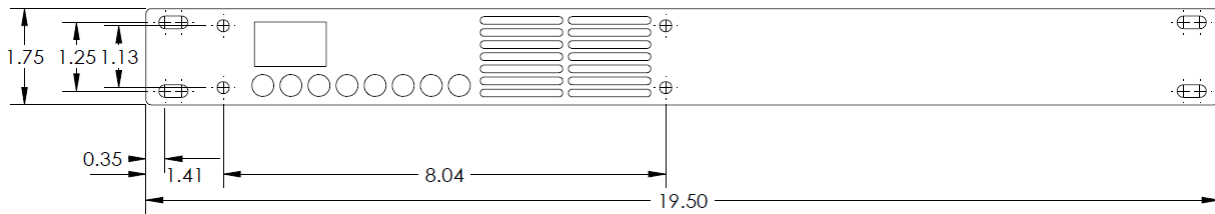

Figure 15: Dimensioned single rack mount faceplate drawing.

8.2 Standalone Mounting Configuration

A standalone mounting configuration option is available if rack mounting is not desired. Figure 16 shows an exploded assembly view of this option. A dimensioned drawing, showing mounting locations is given in Figure 17.

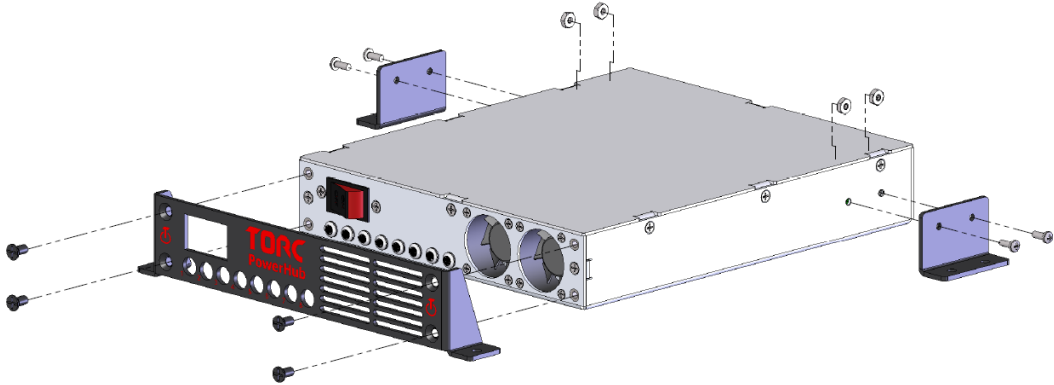

Figure 16: Exploded assembly of the standalone PowerHub mounting option.

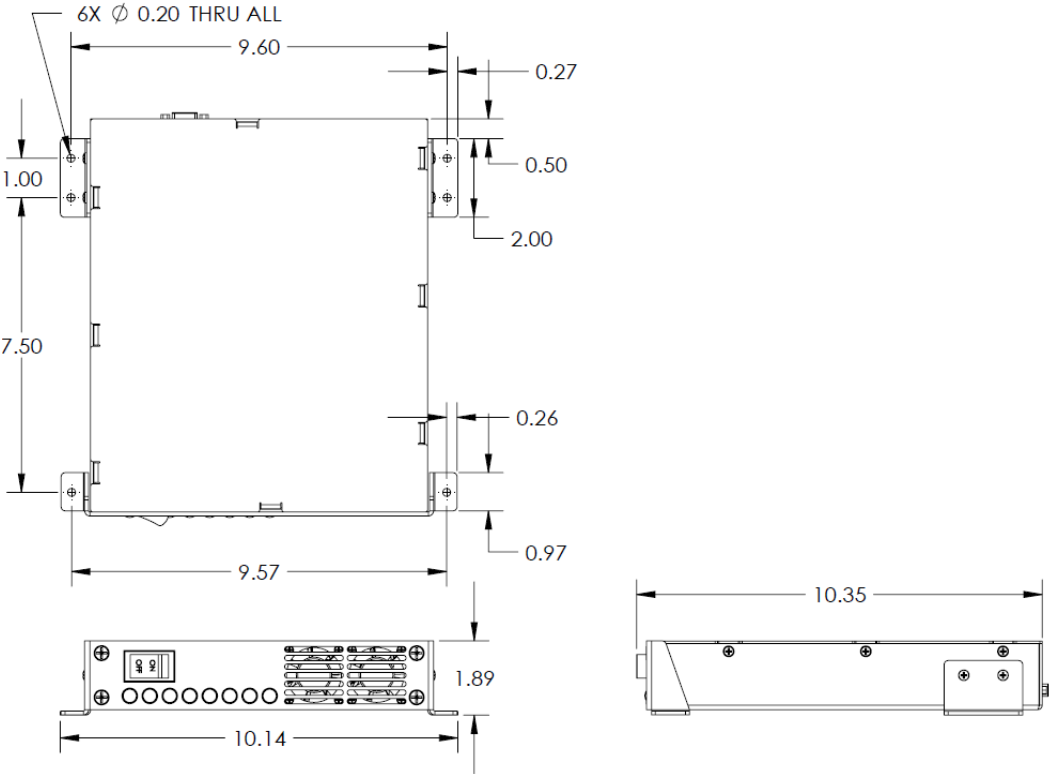

Figure 17: Dimensioned drawing of the standalone PowerHub mounting option.

9 LIMITED WARRANTY

TORC Technologies, LLC (herein referred to as TORC) guarantees that the product(s) you have purchased from TORC are free from defects in materials or workmanship for a period of one year from the original date of purchase. Within this period TORC will, at its sole discretion, repair or replace any components which fail under normal use. This warranty does not cover failures due to abuse, misuse, accident, or unauthorized alterations or repairs.

There are no other warranties, expressed or implied, which extend beyond the description contained herein including the implied warranty of merchantability and fitness for a particular purpose. TORC expressly excludes all other warranties

TORC's liability is limited to the cost of repair or replacement of the product. Such remedy shall be the sole and exclusive remedy for any breach of warranty.

TORC shall not be liable for:

1. Damage to other property caused by any defects in the product, damages based upon inconvenience, loss of use of the product, loss of time, loss of profits, loss of business opportunity, loss of goodwill, interference with business relationships, or other commercial loss, even if advised of the possibility of such damages.
2. Any indirect or other damages, whether incidental, consequential, or otherwise.
3. Any claim against the customer by any other party.

The PowerHub firmware incorporates portions of the lwIP TCP/IP networking stack, originally developed by Adam Dunkels at the Swedish Institute of Computer Science. The source code and full text of the associated license agreement may be downloaded from <http://savannah.nongnu.org/projects/lwip>.